

## MDT 569 M32

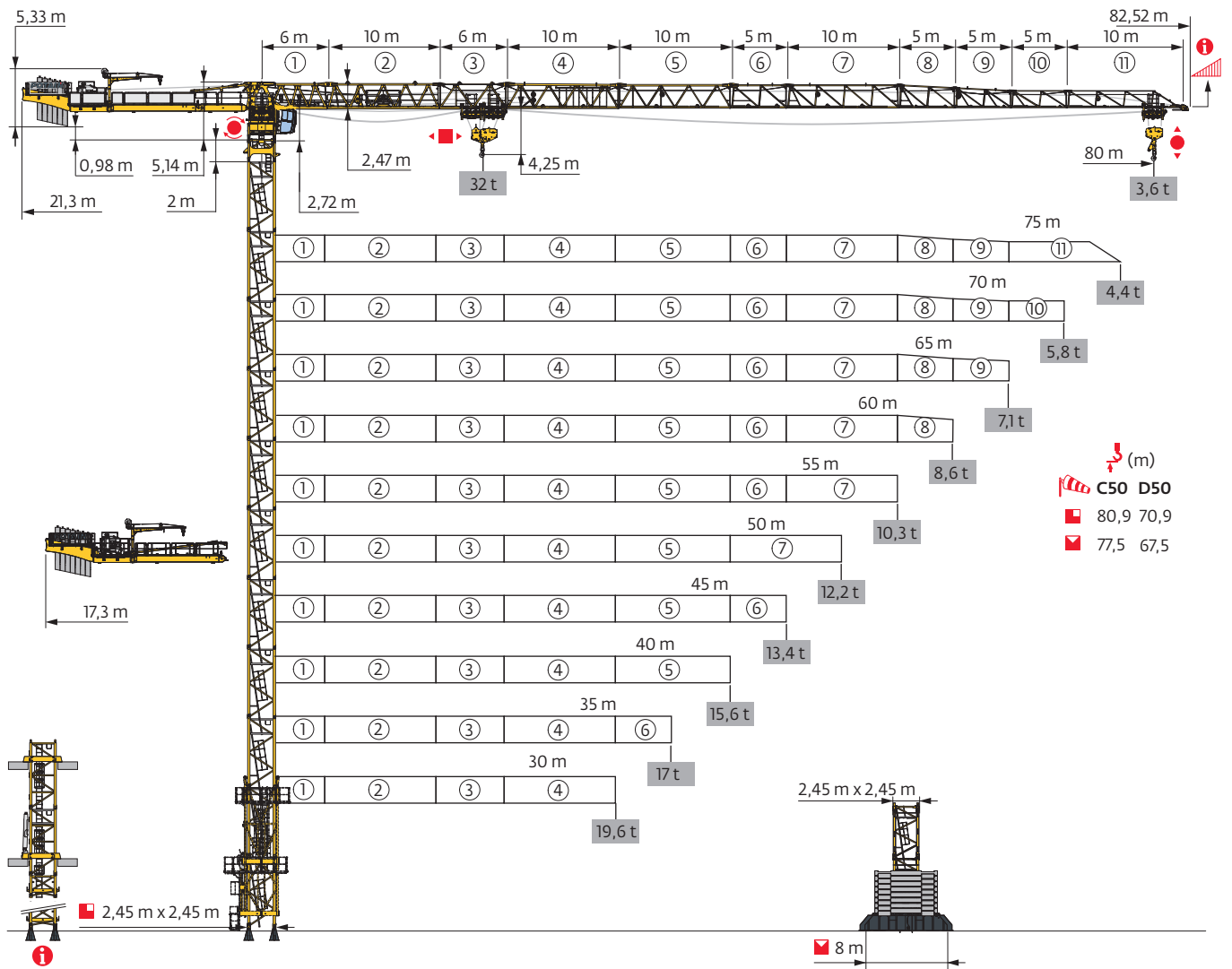

Potain Plus



Power Control

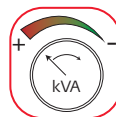

Top Site



Top Tracing 3

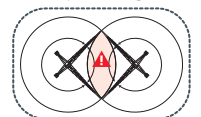

Mât - Réactions / Mast - Reaktionskräfte / Mast - Reactions / Mástil - Reacciones / Torre - Reazioni  
Tramo - Reacções / Реакция опор мачты

□ 2,45 m - P 800B - C50												
ΔΔΔΔ (m)	30	35	40	45	50	55	60	65	70	75	80	
↕ (m)	67,6	69,2	67,6	67,6	67,6	65,9	65,9	65,9	64,2	62,6	62,6	
↕/P* (m)	67,6	69,2	67,6	67,6	67,6	65,9	65,9	65,9	64,2	62,6	62,6	
	2 m	1	1	1	1	1	1	1	1	1	1	
	3,33 m	2	1	2	2	0	0	0	1	2	2	
	5 m	12	13	12	12	12	13	13	13	12	11	
F2 (t)	●	259	262	259	264	261	258	259	257	249	236	243
	■	387	398	386	394	391	381	385	387	385	377	381
F3 (t)	●	166	166	160	163	157	159	158	158	150	137	144
	■	310	317	303	308	303	298	301	304	302	295	297
↕ (m) D50	59,2	59,2	59,2	59,2	59,2	57,6	55,9	55,9	55,9	54,2	54,2	
↕/P* (m) D50	59,2	59,2	59,2	59,2	59,2	57,6	55,9	55,9	55,9	54,2	54,2	

□ 2,45 m - P 854A - C50												
ΔΔΔΔ (m)	30	35	40	45	50	55	60	65	70	75	80	
↕ (m)	80,9	80,9	80,9	79,2	79,2	77,6	77,6	77,6	75,9	75,9	75,9	
↕/P* (m)	80,9	80,9	80,9	79,2	79,2	77,6	77,6	77,6	75,9	75,9	75,9	
	2 m	1	1	1	1	1	1	1	1	1	1	
	3,33 m	0	0	0	1	1	2	2	0	0	0	
	5 m	16	16	16	15	15	14	14	14	15	15	
F2 (t)	●	299	298	299	300	296	295	296	296	288	283	293
	■	565	560	565	554	551	550	556	559	541	549	553
F3 (t)	●	198	194	192	192	185	189	188	187	181	176	185
	■	480	472	474	462	456	460	464	466	450	458	460
↕ (m) D50	69,2	70,9	69,2	69,2	69,2	67,6	67,6	67,6	65,9	65,9	65,9	
↕/P* (m) D50	69,2	69,2	69,2	69,2	69,2	67,6	67,6	67,6	65,9	65,9	65,9	

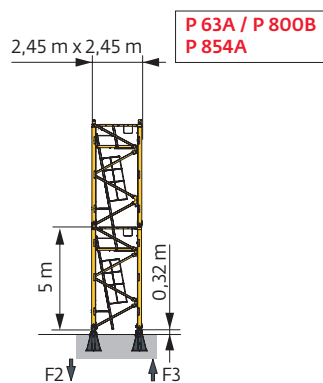

❗ Autres compositions de pylône - Nous consulter. / Andere Turmaufbauten - bitte kontaktieren Sie uns. / Other mast compositions - Please consult us. / Para otras composiciones de mástil - Por favor contáctenos. / Per altre composizioni torre, contattateci. / Para outras composições de coluna - Por favor, consulte-nos. / Для других композиций мачты пожалуйста проконсультируйтесь с нами.

Accès motorisés : compositions de mât, de lest de base et réactions adaptées. / Motorisierter Zugang vom : Mastzusammensetzung, Grundballast und Reaktionskräfte sind angepasst. / Motorized accesses: adapted mast composition, base ballast and reactions. / Accesso a cabina con elevador: Adaptación de composición de mástil, lastre de base y reacciones. / Accessi motorizzati: composizioni elementi torre, zavorre di base e reazioni aggiornate. / Acessos motorizados: composições de coluna, lastro da base e reacções adaptadas. / Лифты : адаптированная композиция мачты, базовый балласт и нагрузки.

**2,45 m - ZY 800 - C50**

FAV (m)	30	35	40	45	50	55	60	65	70	75	80
$\downarrow$ (m)	65,6	67,3	67,3	67,3	65,6	65,6	65,6	63,9	62,3	62,3	60,6
$\downarrow/P_+$ (m)	65,6	65,6	63,9	62,3	60,6	55,6	60,6	63,9	62,3	62,3	60,6
	2 m	1	1	1	1	1	1	1	1	1	1
	3,33 m	1	0	0	1	1	1	2	0	0	1
	5 m	12	13	13	13	12	12	12	11	12	11
Fl (t)	● 149	152	153	157	148	152	152	150	145	144	142
	■ 177	182	185	191	178	189	192	184	178	184	177
$\downarrow$ (m) D50	57,3	57,3	57,3	57,3	57,3	55,6	55,6	55,6	53,9	52,3	52,3
$\downarrow/P_+$ (m) D50	57,3	57,3	57,3	57,3	57,3	55,6	55,6	55,6	53,9	52,3	52,3

**2,45 m - ZY 854 - C50**

FAV (m)	30	35	40	45	50	55	60	65	70	75	80
$\downarrow$ (m)	77,5	77,5	77,5	77,5	77,5	77,5	75,9	75,9	74,2	74,2	72,5
$\downarrow/P_+$ (m)	77,5	77,5	77,5	77,5	77,5	77,5	75,9	75,9	74,2	74,2	72,5
	2 m	1	1	1	1	1	1	1	1	1	1
	3,33 m	0	0	0	0	0	1	1	2	2	0
	5 m	15	15	15	15	15	15	14	14	13	13
Fl (t)	● 191	190	192	198	195	199	196	196	192	192	187
	■ 267	264	267	274	272	282	275	277	275	281	264
$\downarrow$ (m) D50	65,9	65,9	67,5	67,5	67,5	64,2	64,2	64,2	64,2	62,5	62,5
$\downarrow/P_+$ (m) D50	65,9	65,9	67,5	67,5	67,5	64,2	64,2	64,2	64,2	62,5	62,5

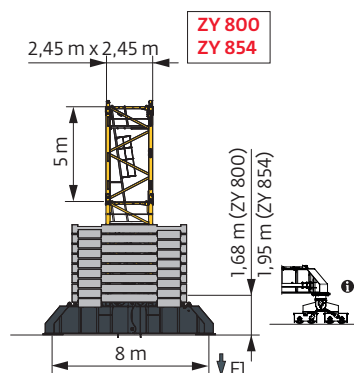

Anchages / Verankerungen / Anchorages / Anclajes / Ancoraggi  
Ancoragem / нкepa



Lest de base / Grundballast / Base ballast / Lastre de base / Zavorra di base  
 Lastro da base / Базовый Балласт

**⚖️ (t) / 📏 2,45 m - ZY 800 - 📦 - C50**

▲▼▲ (m)	30	35	40	45	50	55	60	65	70	75	80
67,3		108	108	108							
65,6	108	96	96	96	84	108	108				
63,9	96	84	84	84	72	96	96	96			
62,3	84	72	72	60	72	84	84	84	96	108	
60,6	72	72	60	60	60	72	72	72	84	96	96
55,6	60	60	48	48	48	60	60	60	84	84	84
50,6	48	48	48	36	36	48	48	60	72	84	84
45,6	36	48	36	36	36	48	48	60	72	72	84
40,6	36	36	36	36	36	48	48	60	72	72	72
35,6	36	36	36	36	36	36	48	60	72	72	72
30,6	36	36	36	36	36	36	48	60	60	60	60
25,6	36	36	36	36	36	36	48	60	60	60	60
20,6	36	36	36	36	36	36	48	60	60	60	60
15,6	36	36	36	36	36	36	48	60	60	60	60

**⚖️ (t) / 📏 2,45 m - ZY 854 - 📦 - C50**

▲▼▲ (m)	30	35	40	45	50	55	60	65	70	75	80
77,5	204	192	192	204	192	216					
75,9	192	180	180	180	180	204	204	204			
74,2	180	168	168	168	168	192	192	192	204	216	
72,5	156	144	144	144	144	168	168	168	180	192	192
67,5	120	108	108	96	96	120	120	120	132	144	144
62,5	72	72	60	60	60	84	84	84	96	96	96
57,5	60	60	48	36	48	60	60	60	72	72	84
52,5	48	48	36	24	36	48	48	60	72	72	72
47,5	36	36	36	24	36	36	36	60	72	72	72
42,5	36	36	36	24	24	36	36	60	60	60	72
37,5	24	36	24	24	24	36	36	48	60	60	60
32,5	24	24	24	24	24	24	36	48	60	60	60
27,5	24	24	24	24	24	24	36	48	48	48	60
22,5	24	24	24	24	24	24	36	48	48	48	48
17,5	24	24	24	24	24	24	36	48	48	48	48

Courbes de charges / Lastkurven / Load curves / Curvas de cargas / Curve di carico / Curvas de carga / Кривые нагрузок



▼▲▲▲ (m)		12	15	20	25	30	35	40	42	45	47	50	52	55	57	60	62	65	67	70	72	75	77	80	m	
▼▲▲▲	32 t	▼▲▲▲	16 t	▼▲▲▲							▼▲▲▲															
80	4,2 → 13,1 4,2 → 14,2	22,9 - 25,1 24,6 - 27	32 27,2 19,1 32 30 21	16 12,9 10,7 9 16 14,2 11,8 9,9	8,5 7,7 7,3 8,5 8 7,4	6,4 5,9 5,6 6,2 5,7 5,4	4,9 4,6 4,4 4,8 4,5 4,3	3,9 3,7 3,5 4 3,9 3,6	3,3 t t P+																	
75	4,2 → 13,6 4,2 → 14,7	23,9 - 26 25,7 - 28	32 28,5 20 32 31,3 22	16 13,5 11,2 9,5 16,6 14,9 12,4 10,5	9 8,2 7,7 9 8,5 7,9	6,8 6,3 6 6,6 6,1 5,8	5 4,7 4,4 5,2 4,9 4,7	4 4,3 4 4,4 t P+																		
70	4,2 → 15,3 4,2 → 16,6	27,1 - 29,4 29,2 - 32	32 32 23,3 17,7 32 32 25,6 19,5	15,7 13,1 11,1 10,5 16 14,4 12,2 11,5	9,6 9,1 8,4 8 10,6 10 9,3 8,8	8,2 7,8 7,2 6,9 6,4 6,2	5,8 5,5 5,2 5,8 t P+																			
65	4,2 → 16,8 4,2 → 18,2	29,7 - 32,3 32 - 35	32 32 26 19,9 32 32 28,6 21,8	16 14,6 12,5 11,8 17,4 16 13,7 12,8	10,8 10,3 9,5 9,1 11,7 11,1 10,2 9,7	8,4 8,1 7,6 7,2 8,5 7,9 7,6 7,1	6,8 t t P+																			
60	4,2 → 17,9 4,2 → 18,4	31,7 - 34,5 34,1 - 36,8	32 32 28 21,5 32 32 29,4 23	17,1 15,7 13,4 12,7 18,7 16 14,6 13,8	11,7 11,1 10,3 9,8 11,9 11 10,4 9,6	9,1 8,7 8,2 t 9,2 8,6 t P+																				
55	4,2 → 18,4 4,2 → 18,7	32,6 - 35,5 34,7 - 37,3	32 32 29 22,2 32 32 29,9 23,4	17,8 16 13,9 13,2 17 16 14,8 14	12,1 11,5 10,7 10,2 12,3 11,5 11 10,3	9,5 t t P+																				
50	4,2 → 19,5 4,2 → 19,6	34,7 - 37,8 36,6 - 39,2	32 32 31,1 23,9 32 32 31,4 24,6	19,2 16,8 15,6 14,8 20,1 16,8 15,6 14,8	13 12,4 11,5 t 13,1 12,2 t P+																					
45	4,2 → 19,6 4,2 → 19,6	34,8 - 38 35,8 - 38,4	32 32 31,3 24 32 32 31,3 24,2	19,3 16 15 14,2 16,4 15,3 14,5 13,4	13,1 t t P+																					
40	4,2 → 19,7 4,2 → 19,8	35 - 38,1 36,5 - 39,2	32 32 31,4 24,1 32 32 31,6 24,8	19,4 16 15,1 t 20,2 16,8 15,6 t P+																						
35	4,2 → 20,1 4,2 → 20,1		32 32 32 24,7 32 32 32 25,1	19,8 16,4 t 20,3 17 t P+																						
30	4,2 → 19,5 4,2 → 19,5		32 32 31,2 23,9 32 32 31,2 24,1	19,2 t 19,6 t P+																						

▼▲▲▲ = ▼▲▲▲ - 1,98 t max.



▼▲▲▲ (m)		12	15	20	25	30	35	40	42	45	47	50	52	55	57	60	62	65	67	70	72	75	77	80	m	
▼▲▲▲	32 t	▼▲▲▲	16 t	▼▲▲▲							▼▲▲▲															
80	3,4 → 13,1 3,4 → 14,1	22,7 - 23,2 24,4 - 25	32 27 18,8 32 29,8 20,8	14,5 11,4 9,1 7,5 16 12,7 10,2 8,4	6,9 6,2 5,8 5,2 7,8 7 6,5 5,8	4,8 4,3 4 3,6 4,6 4,2 3,9 3,5	2,85 2,55 2,4 2,15 2,75 2,5 2,3 2,1	1,95 1,75 t t P+																		
75	3,4 → 13,5 3,4 → 14,6	23,6 - 24,1 25,4 - 26	32 28,2 19,8 32 31,1 21,8	15,3 12,1 9,8 8 7,5 16,4 13,4 10,9 9	6,7 6,3 5,7 5,3 7,5 7 6,4 6	4,8 4,5 4,1 3,8 4,6 4,4 4 3,7	2,95 2,8 2,5 t 3,4 3,2 2,9 t P+																			
70	3,4 → 15,2 3,4 → 16,4	26,5 - 27,1 28,6 - 29,4	32 32 22,9 17,3 32 32 25,2 19,1	14,1 11,5 9,5 8,9 15,6 12,8 10,7 10	8,1 7,5 6,9 6,5 8,9 8,1 7,7 7,3	5,9 5,6 5,1 4,8 6,2 5,7 5,3 4,9	4,4 4,2 3,8 t 4,6 4,2 t P+																			
65	3,4 → 16,7 3,4 → 18,1	29,4 - 30,1 31,7 - 32,6	32 32 25,8 19,7 32 32 28,4 21,6	16 13,2 11,1 10,4 17,2 14,7 12,3 11,4	9,4 8,9 8,1 7,7 10,3 9,7 8,8 8,3	7,1 6,7 6,2 5,9 7,6 7,1 6,5 6,2	5,4 t 5,7 t P+																			
60	3,4 → 17,8 3,4 → 18,3	31,4 - 32,1 33,8 - 34,2	32 32 27,8 21,3 32 32 29,2 22,8	16,9 15,6 13,2 12,4 18,5 16 14,6 13,8	11,3 10,6 9,6 9 12,1 11,3 10,3 9,7	8,9 8,4 7,8 7,4 8,3 7,8 7,2 t P+																				
55	3,4 → 18,4 3,4 → 18,7	32,6 - 33,4 34,7 - 35	32 32 29 22,2 32 32 29,9 23,4	17,8 16 13,9 13,2 17 16 13,6 12,8	10,9 10,3 9,5 9 11,8 11,1 10,3 9,8	8,3 t 9,1 t P+																				
50	3,4 → 19,5 3,4 → 19,6	34,7 - 35,5 36,6 - 36,9	32 32 31,1 23,9 32 32 31,4 24,6	19,2 16,8 14,5 13,6 20,1 16,8 14,5 13,6	12,5 11,9 11 t P+ 12,5 11,9 11 t P+																					
45	3,4 → 19,6 3,4 → 19,6	34,8 - 35,6 35,8 - 36,1	32 32 31,3 24 32 32 31,3 24,2	19,3 16 13,9 13 16,4 14,1 13,3 12,2	11,9 t t P+																					
40	3,4 → 19,7 3,4 → 19,8	35 - 35,8 36,5 - 36,9	32 32 31,4 24,1 32 32 31,6 24,8	19,4 16 13,9 t 20,2 16,8 14,5 t P+																						
35	3,4 → 20,1 3,4 → 20,1		32 32 32 24,7 32 32 32 25,1	19,8 16,4 t 20,3 17 t P+																						
30	3,4 → 19,5 3,4 → 19,5		32 32 31,2 23,9 32 32 31,2 24,1	19,2 t 19,6 t P+																						



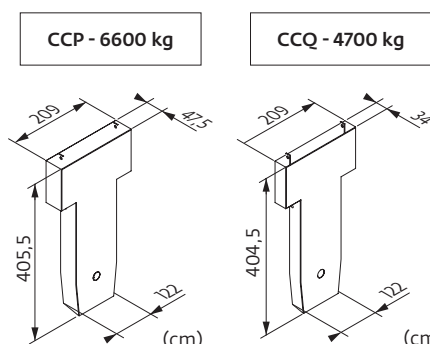

▼▲▲▲ = ▼▲▲▲ - 0,65 t max.

Lest de contre-flèche / Gegenauslegerballast / Counter-jib ballast / Lastre de contra-flecha / Zavorra di controbraccio / Lastro da contra lança / Противовес стрелы













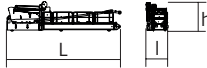
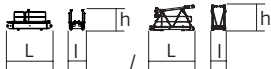

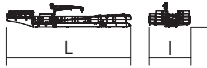
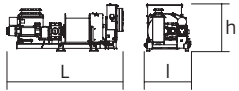
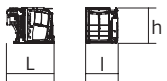
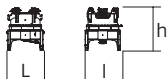

▼▲▲▲	6600 kg	4700 kg	▲▲▲ (kg)
80 m	6	0	39600
75 m	5	1	37700
70 m	5	1	37700
65 m	5	1	37700
60 m	4	2	35800
55 m	3	3	33900
50 m	7	0	46200
45 m	5	2	42400
40 m	6	0	39600
35 m	4	2	35800
30 m	4	1	31100

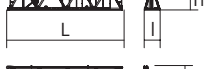

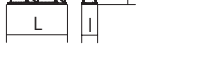

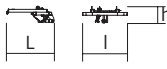





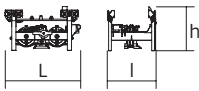

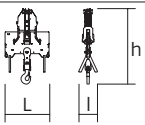

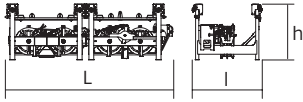

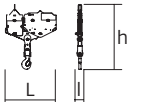

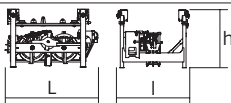

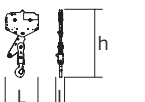

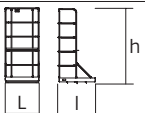
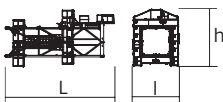

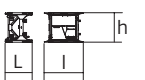
Encombrenment et poids / Abmessungen und Gewicht / Dimensions and weight / Dimensiones y peso / Ingombro e peso  
 dimensões e pesos / габаритные размеры и вес

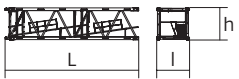
Partie tournante / Drehender Kranteil / Slewing crane part / Parte giratoria  
 Parte rotante / Parte rotativa / Поворотная часть :  80 m -  -  -  150 HPL™

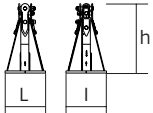
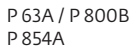
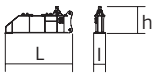

Partie tournante / Drehender Kranteil / Slewing crane part Parte giratoria / Parte rotante / Parte rotativa / Поворотная часть	L (m)	l (m)	h (m)	kg (+/- 5%)	
Contre-flèche / Gegenausleger Counter-jib / Contra-flecha Controbraccio / Contra-lança Контр-стрела		12	2,2	2,5	13465
		12	2,2	2,5	17885
		11,92	2,2	2,81	13415
		4,56 4,34	1,62 1,38	2,02 2,46	4350 3170
		16,25	6,69	3,93	15630
		20,26	6,69	3,93	19660
Treuil de levage (+ câble) / Hubwerk (+ Seil) Hoisting winch (+ rope) / Mecanismo de elevación (+ cabo) Argano di sollevamento (+ fune) Guincho de elevação (+ cabo) Подъемная лебедка (+ канатом)	 150 HPL™	4,82	1,83	1,97	7575
Cabine / Kabine Cab / Cabina Cabina / Cabina Кабина	 Ultra View	3,36	2,28	2,49	3000
Pivot / Krankopf Towerhead / Pivote Portaralla / Pivot Секция поворотной части	 2,45 m	2,68	2,49	3,03	12640
		6,68	2,49	3,03	15640
Élément de flèche / Auslegerelement Jib section / Elemento de flecha Elemento di braccio / Elemento de lança Секция стрелы	 ①	7,7	1,55	2,48	8665
	 ②	10,35	2,27	2,47	8770
	 ③	6,37	1,38	2,43	3245
	 ④	10,38	1,38	2,37	4295
	 ⑤	10,4	1,38	2,22	3225
	 ⑦	10,25	1,38	2,2	2265
	 ⑪	10,08	1,38	1,55	830
	 ⑥	5,36	1,38	2,22	1365
	 ⑧	5,3	1,38	2,13	780
	 ⑨	5,21	1,38	1,87	665
 ⑩	5,18	1,38	1,57	565	
	1,67	1,57	0,58	265	

			L (m)	I (m)	h (m)	kg (+/- 5%)
Chariot / Laufkatze Trolley / Carrello Carro / Carro-distribuidor Тележка			2,63	1,75	1,58	1215
Moufle / Hubflasche Pulley block / Aparejo Bozzello / Cadernal Полиспаст			1,89	0,8	3,18	1415
Chariot / Laufkatze Trolley / Carrello Carro / Carro-distribuidor Тележка			4,2	1,8	1,5	1460
Moufle / Hubflasche Pulley block / Aparejo Bozzello / Cadernal Полиспаст			2,3	0,33	2,95	1310
Chariot / Laufkatze Trolley / Carrello Carro / Carro-distribuidor Тележка			2,1	1,8	1,5	780
Moufle / Hubflasche Pulley block / Aparejo Bozzello / Cadernal Полиспаст			1,52	0,33	3,05	810
Nacelle de chariot / Arbeitsbühne an der Laufkatze Trolley inspection platform / Gondola de carro Navicella-carrelino / Cesta do carro Платформа тележки			0,96	1,05	2,12	55
<b>Pyłõne / Kranturm / Crane tower Mástil / Torre / Torre Башня крана</b>						
T 851			11,18	4,84	5,8	15750
K 84/K 84-2			2,24	3,24	2,5	3050
KRM 849B K 85/KR 84B2 KM 850.10B KM 850.14B K 85/KR 84A2 KMT 850.10A KMT 850.14A K 849A KMT 849A KR 849A KRMT 849A KRMT 849C KMT 850.10C			10,24 10,24 10,32 10,32 5,24 5,32 5,32 5,23 5,23 5,23 5,23 3,57 3,65	2,55 2,54 2,54 2,54 2,54 2,54 2,54 2,53 2,55 2,53 2,55 2,55 2,54	2,53 2,5 2,51 2,51 2,5 2,51 2,51 2,5 2,53 2,5 2,53 2,53 2,53 2,51	7800 9635 10070 11190 5550 5450 5990 3400 3150 4290 4090 3205 4230
Pieds de scellement / VerankerungsfüÙe Fixing angles / Pie de empotramiento Montante da anngare / Angulos fixadores анкера			0,75 0,9	0,75 0,9	1,28 1,5	465 940
1/2 Bras de croix / 1/2 Fundamentkruztråger 1/2 Cross girder / 1/2 Braço en cruz 1/2 Braccio croce / 1/2 Braço da cruz 1/2 Поперечная балка			5,68 5,7	0,98 0,98	1,92 2,27	4720 6430
Bras de croix / Fundamentkruztråger Cross girder / Braço en cruz Braccio croce / Braço da cruz Поперечная балка			11,96 11,9	1,39 1,42	1,92 2,27	10075 14000

Mécanismes / Triebwerke / Mechanisms / Mecanismos / Meccanismi  
 Mecanismos / Механизмы

400 V - 50 Hz													ch - PS hp	kW	
	<b>150 HPL™ 80</b>	m/min t	35,5 16	45,5 12	62,5 8	103 4	151 1,8	18 32	23 24	31,5 16	53,5 8	75,5 4,7	150	110	506 m
	<b>15 DVF 16 Optima</b>	m/min	0 → 33 (32 t) 0 → 50 (20 t) 0 → 67 (10 t) 0 → 100 (2,5 t)										15	11	
	<b>RVF 174 Optima+</b>	tr/min U/min rpm						0 → 0,7					4 x 10	4 x 7,5	

	<b>IEC 60204-32</b>	
400 V (+10% -10%) 50 Hz	170 → 110 kVA	

	<b>FR</b>	<b>DE</b>	<b>EN</b>	<b>ES</b>	<b>IT</b>	<b>PT</b>	<b>RU</b>
	Profil de vent suivant EN 14439 C50-D50	Windbedingungen gemäß EN 14439 C50-D50	Wind conditions according to EN 14439 C50-D50	Conformidad de los condiciones de viento EN 14439 C50-D50	Condizioni del vento secondo EN 14439 C50-D50	Perfil de vento conforme EN 14439 C50-D50	Ветровой режим в соответствии с EN 14439 C50-D50
	Appel de flèche	Auslegerüberhöhung	Jib elevation	Elevación de la flecha	Inclinazione braccio	Desvio da lança	подъем стрелы
	Équipements standards	Standardausrüstungen	Standard equipment	Equipamiento de serie	Equipaggiamento standard	Equipamento de série	Стандартное оборудование
	Équipements optionnels	Sonderausrüstungen	Options	Equipamiento opcional	Equipaggiamento in opzione	Equipamento opcional	Дополнительное оборудование (опция)
	Fonction Potain Plus : Courbes de charges Plus	Funktion Potain Plus: Plus-Lastkurven	Potain Plus function: Plus load curves	Función Potain Plus: Diagrama de cargas Plus	Funzione Potain Plus: Curve di carico Plus	Função Potain Plus: Diagrama de cargas Plus	Функция контроля мощности Potain Plus: Диаграммы грузоподъемности Plus
	Hauteurs sous crochet associées aux courbes de charges Plus	Hakenhöhen mit Plus-Lastkurven	Hook heights with Plus load curves	Altura bajo gancho, usando el diagrama de cargas Plus	Altezze sotto gancho con curve di carico Plus	Altura livre, utilizando o diagrama de cargas Plus	Высота под крюком для повышенной вместимости Plus
	Réactions en service	Reaktionskräfte in Betrieb	Reactions in service	Reacciones en servicio	Reazioni in servizio	Reacções em serviço	Реакция при работе
	Réactions hors service	Reaktionskräfte außer Betrieb	Reactions out of service	Reacciones fuera de servicio	Reazioni fuori servizio	Reacções fora de serviço	Реакция в покое
	Poids total du lest	Ballast-Gesamtgewicht	Total ballast weight	Peso total del lastre	Peso totale della zavorra	Peso total do lastro	Общий вес балласта
	Camion 13,4 m	Lkw 13,4 m	Lorry 13,4 m	Camión 13,4 m	Camion 13,4 m	Camião 13,4 m	Рзровой автомобиль 13,4 м
	Conteneur High Cube 40', et/ou Flat Rack 20'	Container High Cube 40', und/oder Flat Rack 20'	Container High Cube 40', and/or Flat Rack 20'	Contenedor High Cube 40', y/o Flat Rack 20'	Container High Cube 40', e/o Flat Rack 20'	Contentor High Cube 40', e/ou Flat Rack 20'	40-футовый контейнер повышенной вместимости High Cube, и/или 20-футовая открытая платформа Flat Rack
	Levage	Heben	Hoisting	Elevación	Sollevamento	Elevação	Подъем
	Distribution	Katzfahren	Trolleying	Distribución	Distribuzione	Distribuição	Перемещение по стреле
	Orientation	Schwenken	Slewing	Orientación	Rotazione	Rotação	Поворот
	Translation	Kranfahren	Travelling	Traslación	Traslazione	Translação	Перемещение крана
	Puissance requise	Erforderliche Leistung	Required power	Potencia Necesaria	Potenza richiesta	Potência Necessária	Потребляемая мощность
	Fonction Power Control : vitesses treuils adaptées à la puissance disponible	Funktion Power Control: Geschwindigkeiten der Triebwerke werden an die verfügbare Leistung angepasst	Power Control Function: winch speeds adapted to the available power	Función Power Control: marchas de los cabrestantes adaptadas a la potencia disponible	Funzione Power Control: velocità degli argani adattate alla potenza disponibile	Função Power Control: velocidades de guincho adaptadas à potência disponível	Функция контроля мощности Power Control: регулировка скорости лебедок в зависимости от доступной мощности
	Nous consulter	Auf Anfrage	Consult us	Consultarnos	Consultateci	Consultar-nos	Проконсультируйтесь у нас
	Document commercial non contractuel. Pour toute information technique se référer à la notice correspondante.	Unverbindliches Vertriebsdokument. Für technische Informationen, siehe die entsprechenden Anweisungen.	This commercial document is not legally binding. For any technical information, please refer to the corresponding instructions.	Documento comercial no contractual. Para cualquier información técnica, ver la noticia correspondiente.	Documento commerciale non vincolante, per tutte le informazioni tecniche fare riferimento al catalogo istruzioni.	Documento comercial não contratual. Para qualquer informação técnica complementar consultar as respectivas instruções.	Этот коммерческий документ не является юридически обязательным. Для получения технической информации, см. соответствующие инструкции.

