

# NATIONAL CRANE®

## NBT30H-2 Series Product Guide

ASME B30.5 • Imperial 85%



### Features

- 27,2 t (30 USt) rating in both standard and tractor mount configurations
- Three (3) four-section boom length options: 33,5 m (110 ft), 30,5 m (100 ft) and 21,0 m (69 ft)
- Color graphical Rated Capacity Limiter (RCL)
- Dual-station manual controls
- Out and Down outriggers with three outrigger configurations

# NATIONAL CRANE NBT30H-2 SERIES

The NBT30H-2 Series delivers 27,2 t (30 USt) maximum capacity; 36,27 m (119 ft) maximum tip height (main boom); 49,68 m (163 ft) maximum tip height (boom with jib).

## Features

### > Boom

The 33,5 m (110 ft) four-section boom is the longest in its size range. The longer boom allows the operator to perform more lifts without the use of a jib, reducing setup time and improving efficiency. A 30,5 m (100 ft) four-section boom is also available for applications that require a shorter overall length requirement. A 21,0 m (69 ft) four-section boom is the standard boom for the tractor mount configuration.

### > Graphical Rated Capacity Limiter (RCL)

The Graphical Rated Capacity Limiter (RCL) is standard on all NBT30H-2 Series machines. The RCL system displays all crane load lifting values simultaneously while providing real-time information about the crane and truck operating system and includes work area definition system (WADS) and operating limits. The RCL is also weather resistant and visible in full or low light. Includes on-board diagnostics of all electronics allows for ease of service.

### > Dual side control station

Traditional mechanical control levers and layout with modern features and benefits located on both sides of the crane. Efficient load-sensing hydraulic system allows for optimum multi-functioning from the crane and integration of the optional radio remote controls providing the operator greater flexibility. Automotive switches and wiring, and electric over hydraulic outrigger control pendant allows for optimum performance and control. Electronic engine start/stop switches with foot pedal throttle control at each side. The RCL graphical display is mounted to a rotating arm for use at either control station.

### > Outriggers

Two sets of out and down-style outriggers allow operation in multiple configurations with 6 m (20 ft) full-span, a 4,2 m (14 ft) mid-span setting, and a fully retracted outrigger spread. Main outriggers are equipped with removable ball and socket polymeric foot pads. Independent control of each outrigger beam and jack cylinder using a tethered pendant control for optimum setup visibility and includes a level indicator (sight bubble).

### > Options and Lift Solutions

- Hydraulic hose reels
- Bulkhead and flat-bed options
- Factory installed tool box options
- Camera systems



*\*May be shown with optional equipment*



# Job site benefits

## Performance you can rely on

- Reap the ROI benefits from modern features in a more affordable package
- Class leading tip height when equipped with the 33,5 m (110 ft) four-section boom
- User-friendly, dual-station mechanical controls and fully integrated control system with all truck engine information available at the crane control station
- Modern, efficient load sensing hydraulic system with a single piston pump simplifying installation, hose routing and improved multifunction operation
- Two-speed hoist provides faster winch payout and pickup of unloaded cable
- Utilization enhancing options such as the 2-stage jib, personnel baskets and wireless radio remotes for optimum versatility
- Internal anti-two-block wire routing eliminates potential for damage
- Pre-painted components reduce the possibility of rust, improve serviceability and enhance the appearance of the machine
- Tractor mount configuration available for oil field and utility applications; designed for oil field work, but can fill other multiple roles in any fleet



**What you need, when you need it.**

**Get right to work with the right equipment** — Manitowoc Finance gives you access to flexible, affordable financing you can use to seize profitable new opportunities as they arise.

**Feel confident in your investment** — rest easy with the assurance of the world's most advanced crane service and support network.

# Beatings

- Dimensions .....5
  
- Mounting configurations .....7
  
- Working range - 100 foot boom .....9
  
- Load chart - 100 foot boom..... 10
  
- Working range - 110 foot boom .....13
  
- Load chart - 110 foot boom.....14
  
- Working range - 69 foot boom .....17
  
- Load chart - 69 foot boom ..... 18
  
- Specifications ..... 19
  
- Symbols glossary ..... 22

# Dimensions

## Standard Mount Configuration

Tailswing Radius  
R1759 mm (R69.25")

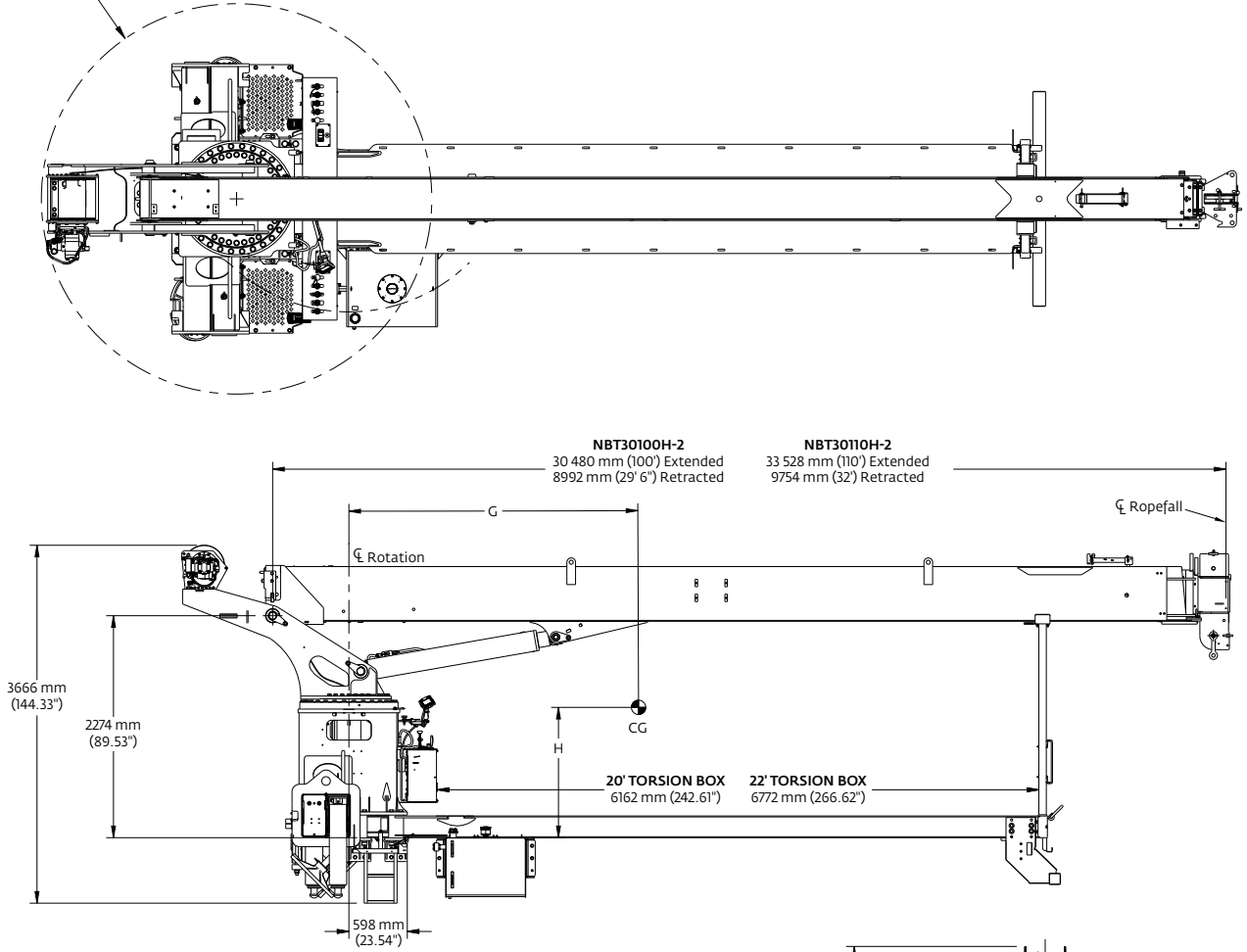

G CENTER OF GRAVITY FROM CENTERLINE				
Boom length	G	H	Dry weight*	With oil weight*
30,48 m (100 ft)	198 cm (77.8 in)	162 cm (63.9 in)	9367 kg (20,650 lb)	9698 kg (21,380 lb)
33,52 m (110 ft)	219 cm (86.1 in)	166 cm (65.4 in)	9739 kg (21,470 lb)	10 070 kg (22,200 lb)

\* Above weights do not include reservoir, RSOD, jib, PTO, pump, BED.

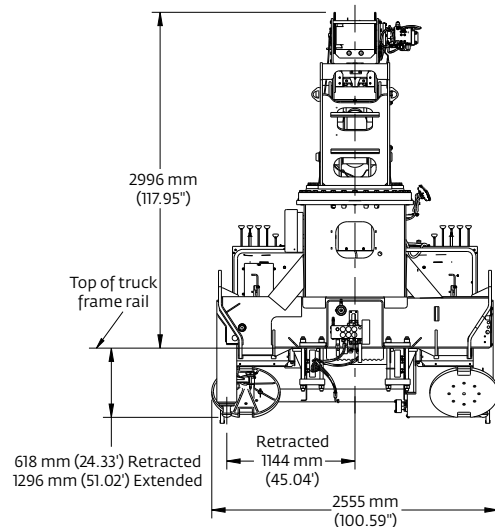

# Dimensions

## Tractor Mount Configuration

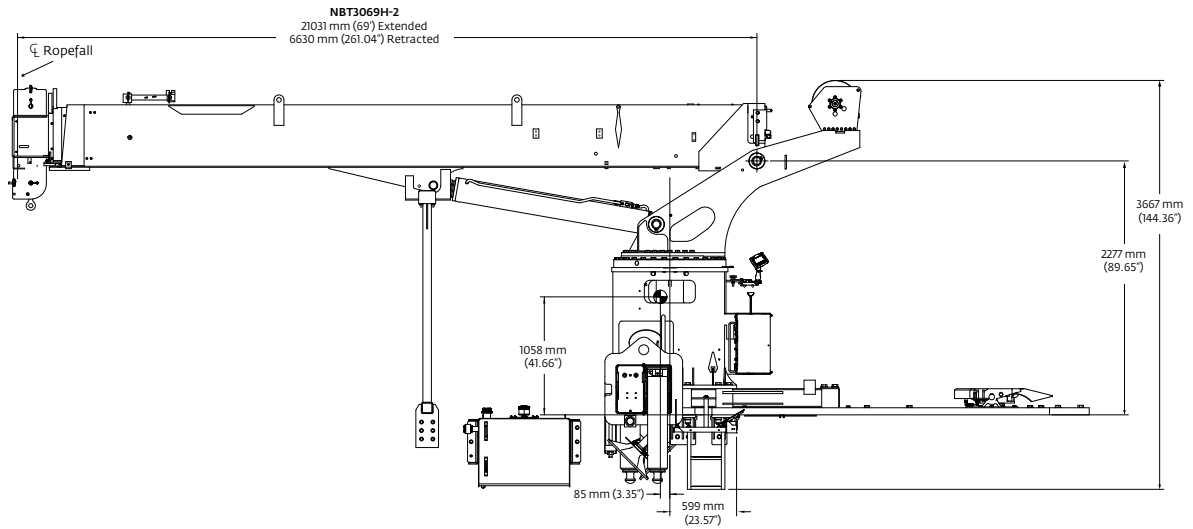
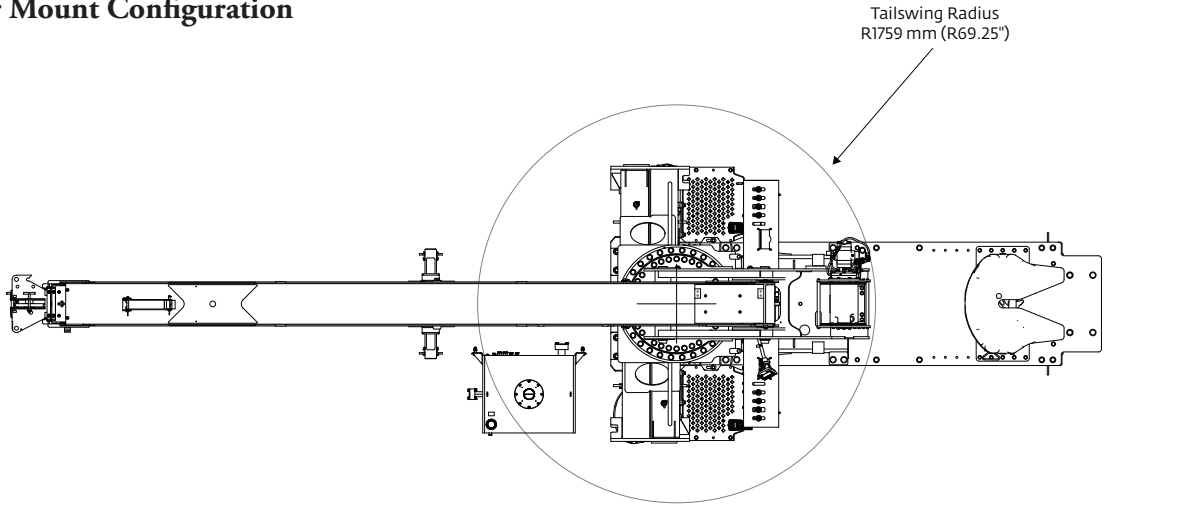

G CENTER OF GRAVITY FROM CENTERLINE				
Boom length	G	H	Dry weight*	With oil weight*
21,03 m (69 ft)	198 cm (77.8 in)	162 cm (63.9 in)	10405 kg (22,940 lb)	10737 kg (23,670 lb)

\* Above weights do not include reservoir, RSOD, jib, PTO, pump, BED.

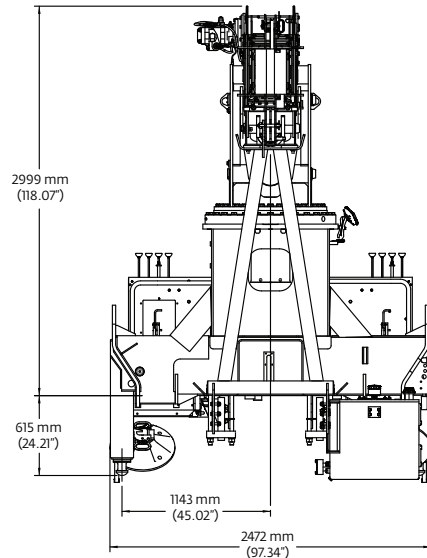

# Mounting configurations

The mounting configuration is based on an 85% stability factor. If the bare truck weight requirements are not met, counterweight will be required. The complete unit must be installed on the truck in accordance with factory requirements. Since individual truck chassis vary, a test must be performed on the unit to verify actual stability after mounting and installing counterweight (if required). A summary of mounting and truck requirements are:

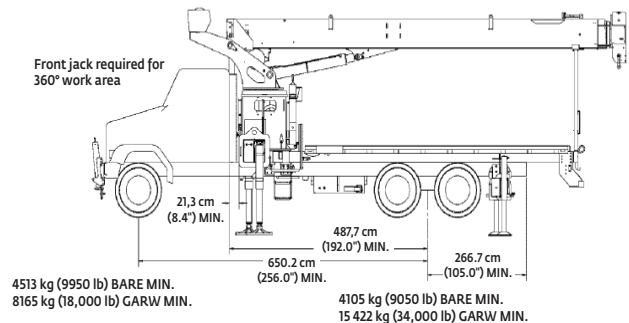

## For 180° working area –

Gross Axle Weight Rating Front (GAWR) – 8165 kg (18,000 lb)  
 Gross Axle Weight Rating Rear (GAWR) – 15 455 kg (34,000 lb)  
 Gross Vehicle Weight Rating (GVW) – 23 587 kg (52,000 lb)  
 Wheelbase (WB) – 256 in (6,50 m)  
 Cab to Axle Trunnion (CT) – 4,88 m (192 in)  
 After Frame (AF) – 2,67 m (105 in)  
 Frame Section Modulus (SM) from outrigger to RSOD – 327 cm<sup>3</sup> (20 in<sup>3</sup>) and 759 MPa (110,000 psi) material  
 Bare Chassis Weight for stability prior to installation.  
 Front: 4513 kg (9950 lb)  
 Rear: 4105 kg (9050 lb)

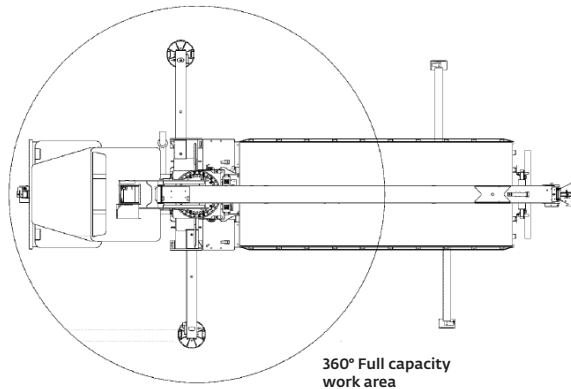

## For 360° working area –

Optional Single Front Stabilizer (SFO)  
 Gross Axle Weight Rating Front (GAWR) – 8165 kg (18,000 lb)  
 Gross Axle Weight Rating Rear (GAWR) – 15 455 kg (34,000 lb)  
 Gross Vehicle Weight Rating (GVW) – 23 587 kg (52,000 lb )  
 Wheelbase (WB) – 256 in (6,50 m)  
 Cab to Axle Trunnion (CT) – 4,88 m (192 in)  
 After Frame (AF) – 2,67 m (105 in)  
 Frame Section Modulus (SM) from front spring hanger to end of after frame – 492 cm<sup>3</sup> (30 in<sup>3</sup>) and 759 MPa (110,000 psi) material  
 Bare Chassis Weight for stability prior to installation.  
 Front: 4513 kg (9950 lb)  
 Rear: 4105 kg (9050 lb)

**Note:** Chassis will require extended front frame rails for SFO addition.

For 360° stability the truck frame must have a 492 cm<sup>3</sup> (30 in<sup>3</sup>) section modulus [372 850 Nm (3,300,000 in-lb) RBM] minimum under the crane frame, 295 cm<sup>3</sup> (18 in<sup>3</sup>) section modulus [223 710 Nm (1,980,000 in-lb) RBM] at the front spring rear hanger, 197 cm<sup>3</sup> (12 in<sup>3</sup>) section modulus [149 140 Nm (1,320,000 in-lb) RBM] through the front spring and 49 cm<sup>3</sup> (3 in<sup>3</sup>) section modulus [37 284 Nm (330,000 in-lb) RBM] at the stabilizer attachment point on each truck frame rail.

# Mounting configurations

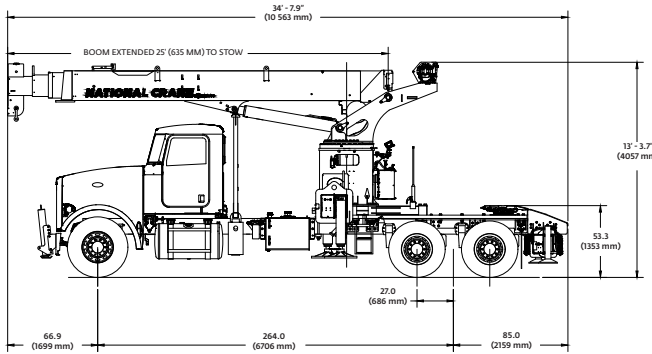

## Recommended Truck Configuration 3 – Tractor Mount NBT3069H-2 TM with four-section boom

**Working area:** 360°

**Gross Axle Weight Rating Front:** 9072 kg (20,000 lb)

**Gross Axle Weight Rating Rear:** 20,865 kg (46,000 lb)

**Gross Vehicle Weight Rating:** 29,937 kg (66,000 lb)

**Wheelbase:** 670 cm (264 in)

**Cab to Axle/Trunnion (CA/CT):** 432 cm (171 in)

**After Frame (AF):** 213 cm (84 in)

**Frame Strength:** 7885 MPa (110,000 PSI)

**Frame Section Modulus (SM) Front Axle to End of**

**Frame:** 573 cm<sup>3</sup> (35 in<sup>3</sup>)

**Stability Weight Front:** 4581 kg (10,100 lb)

**Stability Weight Rear:** 3900 kg (8600 lb)

\* Note: Estimated axle scale weights prior to installation of crane assembly for 85% stability. This configuration as shown does meet Federal Bridge Law.

### Notes:

- Gross Vehicle Weight Rating (GVWR) is dependent on all components of the vehicle (axles, tires, springs, fame, etc.) meeting manufacturers' recommendations; always specify GVWR when purchasing trucks
- Diesel engines require a variable speed governor and energize-to-run fuel solenoid for smooth crane operation; electronic fuel injection is required
- All mounting data is based on a National Crane Series NBT30H-2 with subbase and an 85% stability factor
- The complete unit must be installed in accordance with factory requirements, and a test performed to determine actual stability and counterweight requirements; contact the factory for details
- Transmission neutral safety interlock switch is required
- NBT30H-2 (100 ft boom) with front center stabilizer will be approximate 12,2 m (40 ft) overall length. NBT30H-2 (110 ft boom) will exceed 12,2 m (40 ft) overall length



# Working range

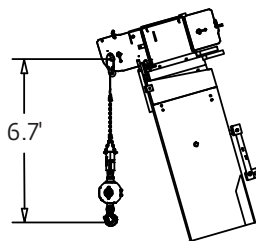
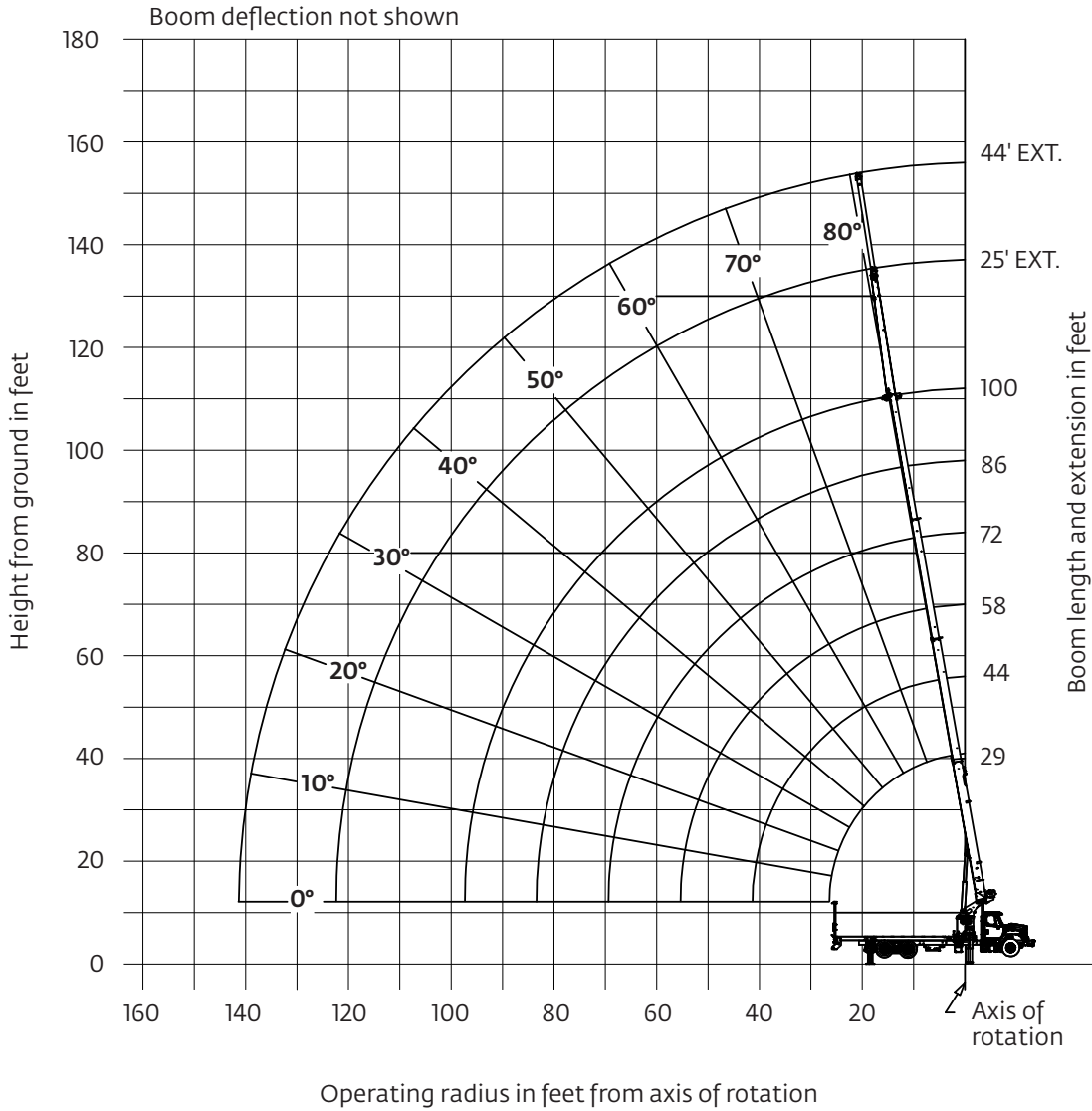
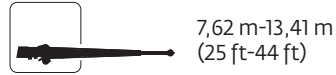

Dimensions are for largest furnished hook block & headache ball, with anti-two block activated

\*Drawing is to show the physical reach of the machine. Always refer to load chart to see what portions of this range are structurally and stability limited.

*THIS CHART IS ONLY A GUIDE AND SHOULD NOT BE USED TO OPERATE THE CRANE.  
The individual crane's load chart, operating instructions and other instructional plates must be read and understood prior to operating the crane.*

# Load chart



8,8 m - 30,5 m  
(29 ft - 100 ft)



6,1 m (20 ft)



360°



Pounds

Feet	29	44-A	58-B	72-C	86-D	100
6	*60,000 (74.3)					
8	44,000 (70.1)	29,100 (77.2)				
10	36,900 (65.9)	29,000 (74.6)				
12	33,450 (61.4)	28,600 (71.9)	28,600 (76.9)			
15	28,300 (54.3)	24,600 (67.7)	23,500 (73.8)	22,900 (77.7)		
20	21,950 (40.6)	21,000 (60.4)	19,000 (68.5)	17,450 (73.6)	16,300 (77.3)	10,650 (79.3)
25	15,700 (20.3)	17,500 (52.4)	16,500 (63)	15,700 (69.4)	13,700 (73.8)	10,450 (76.7)
30		12,800 (43.4)	13,200 (57.2)	13,400 (65)	11,350 (70.2)	10,000 (74)
35		9850 (32.5)	10,100 (50.9)	10,250 (60.3)	10,400 (66.7)	9400 (71.2)
40		7700 (15.8)	7950 (44)	8100 (55.4)	8250 (62.7)	8050 (68)
45			6500 (36.8)	6650 (50.7)	6750 (59)	6850 (64.9)
50			5250 (27.1)	5450 (45.1)	5550 (54.8)	5650 (61.4)
55				4500 (38.9)	4600 (50.4)	4650 (57.9)
60				3700 (31.7)	3800 (45.7)	3900 (54.2)
65				3050 (22.5)	3150 (40.6)	3250 (50.3)
70					2600 (34.8)	2700 (46.2)
75					2100 (28)	2250 (41.8)
80					1700 (18.9)	1800 (37)
85						1450 (31.5)
90						1150 (24.9)
95						900 (15.7)
Minimum boom angle (°) for indicated length (no load)						0
Maximum boom length (ft.) at 0° boom angle (no load)						100

NOTE: ( ) Boom angles are in degrees.

\*This capacity requires optional 9/16" dia. 6x25 IWRC cable.

Lifting Capacities at Zero Degree Boom Angle						
Boom Angle	Main Boom Length in Feet					
	29	44-A	58-B	72-C	86-D	100
0°	10,000 (26.5)	7100 (41.5)	4150 (55.5)	2550 (69.5)	1500 (83.5)	750 (97.5)

NOTE: ( ) Reference radii in feet.

Rated Load Reductions from main boom capacity when lifting over main boom nose with ext. erected (retracted):						
(lb)	2200	1950	1850	1750	1700	1700

80085132

THIS CHART IS ONLY A GUIDE AND SHOULD NOT BE USED TO OPERATE THE CRANE.

The individual crane's load chart, operating instructions and other instructional plates must be read and understood prior to operating the crane.

# Load chart



8,8 m - 30,5 m  
(29 ft - 100 ft)



Stowed



6,1 m  
(20 ft)



360°



Pounds

Feet	29	44-A	58-B	72-C	86-D	100
6	*59,200 (74.3)					
8	43,200 (70.1)	28,500 (77.2)				
10	36,100 (65.9)	28,400 (74.6)				
12	32,650 (61.4)	28,000 (71.9)	28,150 (76.9)			
15	27,500 (54.3)	24,000 (67.7)	23,050 (73.8)	22,550 (77.7)		
20	21,150 (40.6)	20,400 (60.4)	18,550 (68.5)	17,100 (73.6)	16,000 (77.3)	10,400 (79.3)
25	14,900 (20.3)	16,900 (52.4)	16,050 (63)	15,350 (69.4)	13,400 (73.8)	10,200 (76.7)
30		12,200 (43.4)	12,750 (57.2)	13,050 (65)	11,050 (70.2)	9750 (74)
35		9250 (32.5)	9650 (50.9)	9900 (60.3)	10,100 (66.7)	9150 (71.2)
40		7100 (15.8)	7500 (44)	7750 (55.4)	7950 (62.7)	7800 (68)
45			6050 (36.8)	6300 (50.7)	6450 (59)	6600 (64.9)
50			4800 (27.1)	5100 (45.1)	5250 (54.8)	5400 (61.4)
55				4150 (38.9)	4300 (50.4)	4400 (57.9)
60				3350 (31.7)	3500 (45.7)	3650 (54.2)
65				2700 (22.5)	2850 (40.6)	3000 (50.3)
70					2300 (34.8)	2450 (46.2)
75					1800 (28)	2000 (41.8)
80					1400 (18.9)	1550 (37)
85						1200 (31.5)
90						900 (24.9)
95						650 (15.7)
Minimum boom angle (°) for indicated length (no load)						0
Maximum boom length (ft.) at 0° boom angle (no load)						100

NOTE: ( ) Boom angles are in degrees.

\*This capacity requires optional 9/16" dia. 6x25 IWRC cable.

Lifting Capacities at Zero Degree Boom Angle						
Boom Angle	Main Boom Length in Feet					
	29	44-A	58-B	72-C	86-D	100
0°	9200 (26.5)	6500 (41.5)	3700 (55.5)	2200 (69.5)	1200 (83.5)	500 (97.5)

NOTE: ( ) Reference radii in feet.

80085135

THIS CHART IS ONLY A GUIDE AND SHOULD NOT BE USED TO OPERATE THE CRANE.

The individual crane's load chart, operating instructions and other instructional plates must be read and understood prior to operating the crane.

# Load chart



8,8 m - 30,5 m  
(29 ft - 100 ft)



7,6 m - 13,7 m  
(25 ft - 44 ft)



6,1 m  
(20 ft)



360°



Pounds

Feet	25 ft LENGTH	44 ft LENGTH
35	4900 (75.4)	
40	4500 (73.1)	
45	4050 (70.8)	2500 (73.5)
50	3700 (68.4)	2500 (71.7)
55	3400 (65.9)	2500 (69.8)
60	3150 (63.4)	2300 (67.7)
65	3000 (60.9)	2200 (65.6)
70	2400 (57.9)	2100 (63.5)
75	1950 (54.9)	2000 (61.3)
80	1500 (51.8)	1850 (59)
85	1150 (48.5)	1750 (56.5)
90	850 (45)	1400 (53.7)
95	550 (41.4)	1100 (50.7)
100		850 (47.7)
105		600 (44.5)
Min. boom angle for indicated length (no load)	41°	43.5°
Max. boom length at 0° boom angle (no load)	72 ft	58 ft

## Boom extension capacity notes:

- 25 ft and 44 ft extension lengths may be used for single line lifting service.
  - Radii listed are for a fully extended boom with the boom extension erected. For main boom lengths less than fully extended, the rated loads are determined by boom angle. For boom angles not shown, use the rating of the next lower boom angle.
- Warning:** Operation of this machine with heavier loads than the capacities listed is strictly prohibited. Machine tipping with boom extension occurs rapidly and without advance warning.
- Boom angle is the angle above or below horizontal of the longitudinal axis of the boom base section after lifting rated load.
  - Capacities listed are with outriggers properly extended and vertical jacks set.
  - When lifting over the main boom nose with 25 ft or 44 ft extension erected, the outriggers must be fully extended or 50% extended (14 ft spread).

80085138

NOTE: ( ) Boom angles are in degrees.

*THIS CHART IS ONLY A GUIDE AND SHOULD NOT BE USED TO OPERATE THE CRANE.*

*The individual crane's load chart, operating instructions and other instructional plates must be read and understood prior to operating the crane.*

# Working range



33,52 m  
(110 ft)



7,62 m-13,41 m  
(25 ft-44 ft)



6,1 m  
(20 ft)



360°

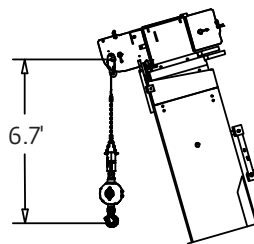
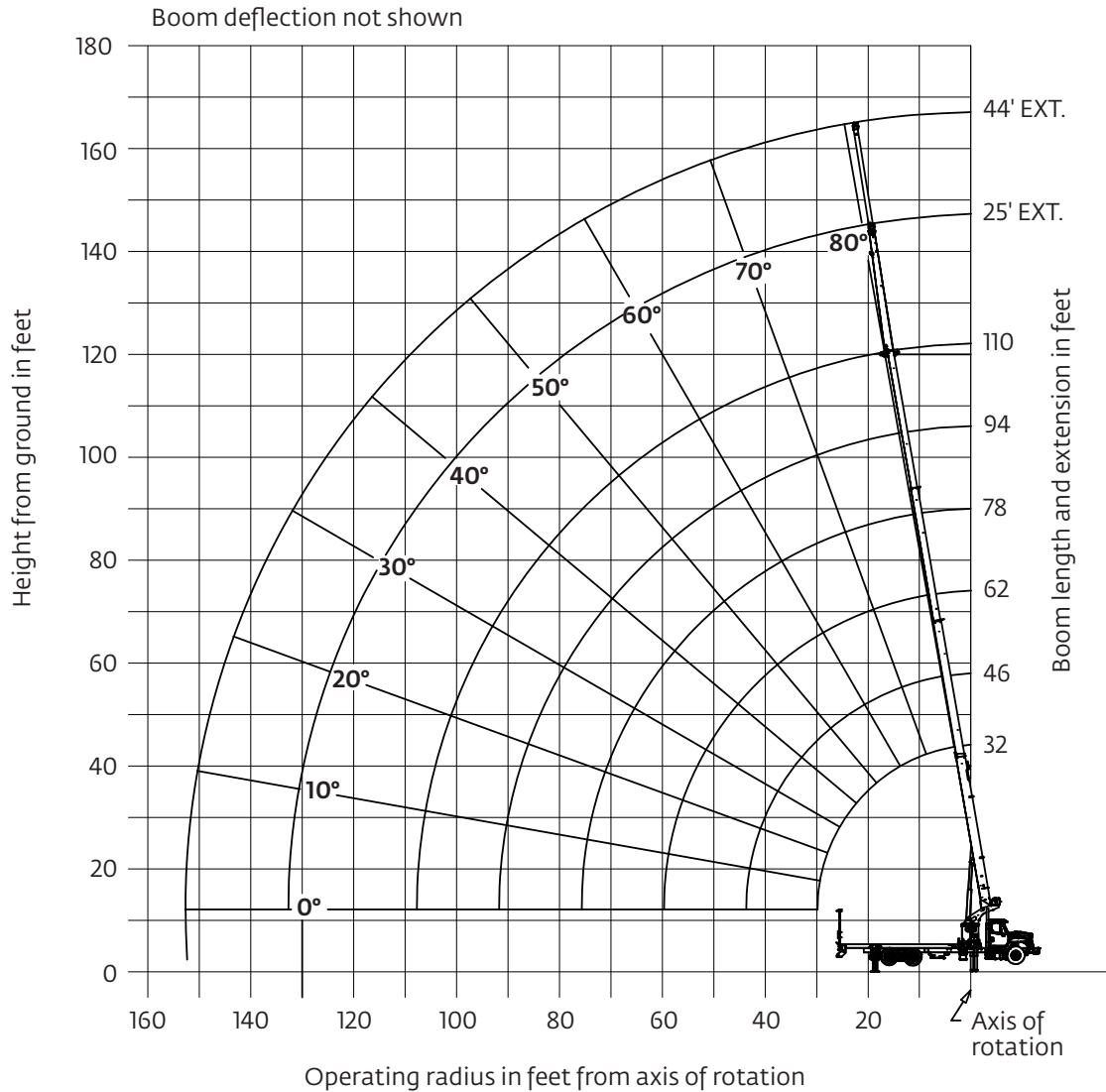





Dimensions are for largest furnished hook block & headache ball, with anti-two block activated

\*Drawing is to show the physical reach of the machine. Always refer to load chart to see what portions of this range are structurally and stability limited.

*THIS CHART IS ONLY A GUIDE AND SHOULD NOT BE USED TO OPERATE THE CRANE.  
The individual crane's load chart, operating instructions and other instructional plates must be read and understood prior to operating the crane.*

# Load chart

 10,1 m - 33,5 m  
(33 ft - 110 ft)
  6,1 m (20 ft)
  360°

 \_\_\_\_\_
  Pounds \_\_\_\_\_

Feet	32	46-A	62-B	78-C	94-D	110
6	*60,000 (75.8)					
8	43,000 (72.1)	29,100 (77.8)				
10	35,900 (68.2)	29,000 (75.3)				
12	32,000 (64.3)	28,000 (72.7)	28,000 (77.8)			
15	27,000 (58.1)	24,000 (68.7)	23,000 (74.9)	19,500 (78.7)		
20	19,500 (46.5)	18,300 (61.8)	17,500 (70)	17,500 (75.1)	16,300 (78.8)	
25	14,900 (31.9)	14,500 (54.3)	14,050 (64.9)	14,000 (71.2)	13,700 (75.7)	10,450 (78.5)
30		12,000 (46.1)	11,600 (59.6)	11,500 (67.2)	11,350 (72.4)	9150 (75.9)
35		9450 (36.4)	9800 (54)	9700 (63)	10,600 (69.3)	8950 (73.5)
40		7250 (24.7)	8050 (47.9)	8250 (58.7)	8450 (65.7)	7700 (70.8)
45			6550 (41.7)	6750 (54.5)	6900 (62.4)	6950 (68)
50			5300 (33.9)	5500 (49.7)	5650 (58.7)	5800 (64.9)
55			4300 (23.9)	4550 (44.4)	4700 (54.8)	4800 (61.8)
60				3700 (38.7)	3800 (50.8)	4000 (58.5)
65				3000 (32)	3100 (46.4)	3250 (55.2)
70				2350 (23.7)	2550 (41.8)	2700 (51.7)
75					2050 (36.7)	2200 (48)
80					1650 (30.9)	1750 (44.1)
85					1250 (23.7)	1400 (39.9)
90					900 (12.9)	1050 (35.3)
95						750 (30)
100						500 (23.7)
Minimum boom angle (°) for indicated length (no load)						0
Maximum boom length (ft.) at 0° boom angle (no load)						94

NOTE: ( ) Boom angles are in degrees.

\*This capacity requires optional 9/16" dia. 6x25 IWRC cable.

Lifting Capacities at Zero Degree Boom Angle						
Boom Angle	Main Boom Length in Feet					
	32	46-A	62-B	78-C	94-D	
0°	8000 (29.5)	4800 (43.5)	2600 (59.5)	1200 (75.5)	850 (91.5)	

NOTE: ( ) Reference radii in feet.

Rated Load Reductions from main boom capacity when lifting over main boom nose with ext. erected (retracted):						
(lb)	2100	1900	1800	1750	1700	1650

80085124

THIS CHART IS ONLY A GUIDE AND SHOULD NOT BE USED TO OPERATE THE CRANE.  
The individual crane's load chart, operating instructions and other instructional plates must be read and understood prior to operating the crane.

# Load chart



10,1 m - 33,5 m  
(33 ft - 110 ft)



Stowed



6,1 m  
(20 ft)



360°



Pounds

Feet	32	46-A	62-B	78-C	94-D	110
6	*59,200 (75.8)					
8	42,200 (72.1)	28,500 (77.8)				
10	35,100 (68.2)	28,400 (75.3)				
12	31,200 (64.3)	27,400 (72.7)	27,550 (77.8)			
15	26,200 (58.1)	23,400 (68.7)	22,550 (74.9)	19,150 (78.7)		
20	18,700 (46.5)	17,700 (61.8)	17,050 (70)	17,150 (75.1)	16,000 (78.8)	
25	14,100 (31.9)	13,900 (54.3)	13,600 (64.9)	13,650 (71.2)	13,400 (75.7)	10,200 (78.5)
30		11,400 (46.1)	11,150 (59.6)	11,150 (67.2)	11,050 (72.4)	8900 (75.9)
35		8850 (36.4)	9350 (54)	9350 (63)	10,300 (69.3)	8700 (73.5)
40		6650 (24.7)	7600 (47.9)	7900 (58.7)	8150 (65.7)	7450 (70.8)
45			6100 (41.7)	6400 (54.5)	6600 (62.4)	6700 (68)
50			4850 (33.9)	5150 (49.7)	5350 (58.7)	5550 (64.9)
55			3850 (23.9)	4200 (44.4)	4400 (54.8)	4550 (61.8)
60				3350 (38.7)	3500 (50.8)	3750 (58.5)
65				2650 (32)	2800 (46.4)	3000 (55.2)
70				2000 (23.7)	2250 (41.8)	2450 (51.7)
75					1750 (36.7)	1950 (48)
80					1350 (30.9)	1500 (44.1)
85					950 (23.7)	1150 (39.9)
90					600 (12.9)	800 (35.3)
95						500 (30)
100						250 (23.7)
Minimum boom angle (°) for indicated length (no load)						0
Maximum boom length (ft) at 0° boom angle (no load)						94

NOTE: ( ) Boom angles are in degrees.

#RCL operating code. Refer to RCL manual for operating instructions.

\*This capacity requires optional 9/16" dia. 6x25 IWRC cable.

Lifting Capacities at Zero Degree Boom Angle						
Boom Angle	Main Boom Length in Feet					
	32	46-A	62-B	78-C	94-D	
0°	7200 (29.5)	4200 (43.5)	2150 (59.5)	850 (75.5)	550 (91.5)	

NOTE: ( ) Reference radii in feet.

80085127

*THIS CHART IS ONLY A GUIDE AND SHOULD NOT BE USED TO OPERATE THE CRANE.*

*The individual crane's load chart, operating instructions and other instructional plates must be read and understood prior to operating the crane.*

# Load chart



10,1 m - 33,5 m  
(33 ft - 110 ft)



7,6 m - 13,7 m  
(25 ft - 44 ft)



6,1 m  
(20 ft)



360°



Pounds

Feet	25 ft LENGTH	44 ft LENGTH
40	4400 (74.8)	
45	4400 (72.9)	2800 (75.2)
50	4100 (70.8)	2700 (73.5)
55	3800 (68.6)	2650 (71.7)
60	3500 (66.5)	2500 (69.8)
65	3000 (63.8)	2300 (67.8)
70	2450 (61.1)	2200 (65.9)
75	1950 (58.4)	1900 (64.2)
80	1550 (55.5)	1600 (61.8)
85	1150 (52.6)	1550 (59.4)
90	800 (49.6)	1400 (56.8)
95		1000 (54.1)
100		750 (51.4)
Min. boom angle for indicated length (no load)	47°	49°
Max. boom length at 0° boom angle (no load)	62 ft	62 ft

80085130

NOTE: ( ) Boom angles are in degrees.

## Boom extension capacity notes:

1. 25 ft and 44 ft extension lengths may be used for single line lifting service.
2. Radii listed are for a fully extended boom with the boom extension erected. For main boom lengths less than fully extended, the rated loads are determined by boom angle. For boom angles not shown, use the rating of the next lower boom angle.  
**Warning:** Operation of this machine with heavier loads than the capacities listed is strictly prohibited. Machine tipping with boom extension occurs rapidly and without advance warning.
3. Boom angle is the angle above or below horizontal of the longitudinal axis of the boom base section after lifting rated load.
4. Capacities listed are with outriggers properly extended and vertical jacks set.
5. When lifting over the main boom nose with 25 ft or 44 ft extension erected, the outriggers must be fully extended or 50% extended (14 ft spread).

*THIS CHART IS ONLY A GUIDE AND SHOULD NOT BE USED TO OPERATE THE CRANE.*

*The individual crane's load chart, operating instructions and other instructional plates must be read and understood prior to operating the crane.*



# Working range

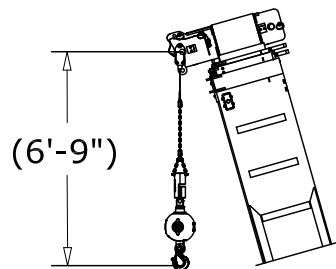
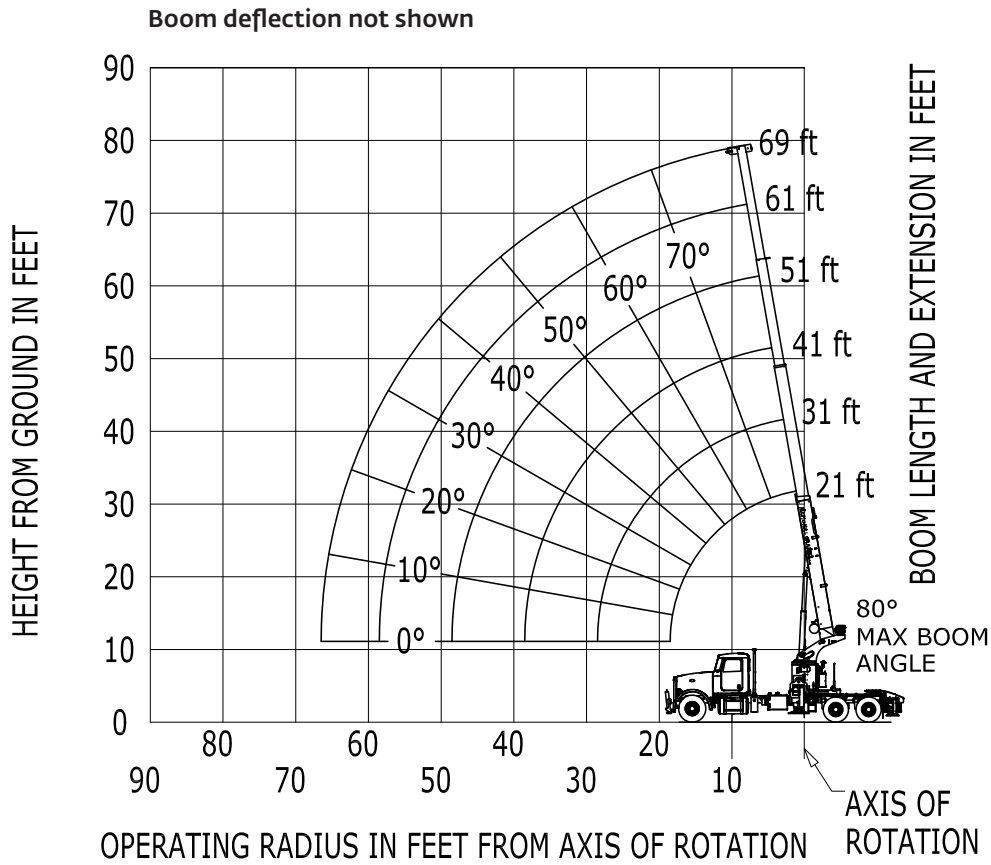

DIMENSIONS ARE FOR HEADACHE BALL WITH ANTI-TWO BLOCK ACTIVATED.

\*Drawing is to show the physical reach of the machine. Always refer to load chart to see what portions of this range are structurally and stability limited.

*THIS CHART IS ONLY A GUIDE AND SHOULD NOT BE USED TO OPERATE THE CRANE.  
The individual crane's load chart, operating instructions and other instructional plates must be read and understood prior to operating the crane.*

# Load chart

69 ft      100%  
Front: 20 ft  
Rear: 18.5 ft      180°

Pounds

Radius in Feet	Main Boom Length in Feet					
	21	31	41	51	61	69
5	60,000					
8	47,500	33,500	33,400			
10	40,300	33,100	32,300	35,000		
12	34,900	32,700	31,100	30,100	29,000	
15	28,600	27,300	25,900	24,900	24,200	19,350
20		21,200	20,300	19,500	18,850	18,450
25		16,550	16,600	16,000	15,450	15,050
30			13,800	13,500	13,050	12,700
35			10,600	10,750	10,850	10,950
40				8650	8750	8950
45				7200	7300	7350
50					6050	6100
55					5100	5150
60						4350
65						3700
<b>Boom angle</b>	<b>Lifting Capacities at Zero Degree Boom Angle</b>					
0°	15,000	10,000	7000	5000	3800	3620

*THIS CHART IS ONLY A GUIDE AND SHOULD NOT BE USED TO OPERATE THE CRANE.  
The individual crane's load chart, operating instructions and other instructional plates must be read and understood prior to operating the crane.*

# Specifications

## Crane functions

Slewing: 2RPM; Boom raise/lower: 30 seconds; Telescope: 90 seconds extend and retract						
1 part line	2 part line	3 part line	4 part line	5 part line	6 part line	7 part line
43,9 m (144 ft) boom jib	30,5 m (100 ft)	22,4 m (75 ft)	18,3 m (60 ft)	15,2 m (50 ft)	13,1 m (43 ft)	11,0 m (36 ft)
46,9 m (154 ft) boom jib	33,5 m (110 ft)	23,8 m (78 ft)	23,8 m (78 ft)	18,9 m (62 ft)	14,0 m (46 ft)	9,8 m (32 ft)

Winch	Average cable supplied	Breaking strength	Lift and speed	Lift and speed	Lift and speed	Lift and speed	Lift and speed	Lift and speed	Lift and speed
Low speed winch	9/16 in Diameter rotation resistant	17 464 kg (38,500 lb)	3493 kg (7700 lb) 48,8 m/min (160 fpm)	6986 kg (15,400 lb) 24,3 m/min (80 fpm)	10 478 kg (23,100 lb) 16,2 m/min (53 fpm)	13 971 kg (30,800 lb) 12,2 m/min (40 fpm)	17 464 kg (38,500 lb) 9,8 m/min (32 fpm)	20 956 kg (46,200 lb) 8,2 m/min (27 fpm)	24 449 kg (53,900 lb) 7,0 m/min (23 fpm)
High speed winch	9/16 in Diameter rotation resistant	17 464 kg (38,500 lb)	1361 kg (3000 lb) 94,4 m/min (310 fpm)	2722 kg (6000 lb) 47,2 m/min (155 fpm)	4083 kg (9000 lb) 31,4 m/min (103 fpm)	5443 kg (12,000 lb) 23,8 m/min (78 fpm)	6804 kg (15,000 lb) 18,9 m/min (62 fpm)	8165 kg (18,000 lb) 15,8 m/min (52 fpm)	9526 kg (21,000 lb) 13,4 m/min (44 fpm)

All winch pulls and speeds in this chart are shown on the fourth layer. Winch line pulls would increase on the first, second and third layers. Winch line speed would decrease on the first, second and third layers. Winch line pulls may be limited by the winch capacity or the ANSI 5 to 1 cable safety factor. These are shown below:

Winch	Fourth layer drum pull	Allowable cable pull
Standard planetary	3493 kg (7700 lb) (low speed) 1361 kg (3000 lb) (high speed)	3492 kg (7700 lb)

Block type	Rating	Weight
Downhaul weight	4,53 t (5 USt)	68 kg (150 lb)
1-sheave Block	10,89 t (12 USt)	122 kg (270 lb)
2-sheave Block	17,24 t (19 USt)	159 kg (350 lb)
3-sheave Block	27,22 t (30 USt)	261 kg (575 lb)

# Specifications

## Super Structure

### Boom

Three options: 8,8 m - 30,4 m (29 ft – 100 ft), four-section with a maximum tip height of 33,22 m (109 ft); 10,1 m - 33,5 m (33 ft – 110 ft), four-section with a maximum tip height of 36,27 m (119 ft); and 21,0 (69 ft) four-section with maximum tip height of 23,77 m (78 ft). All boom options include proportional extension via multi-stage hydraulic cylinder and cable operation, 4-plate, high-strength steel construction, 2-sheave, quick reeve boom nose and Easy-glide wear pads.

### Boom elevation

One (1) double-acting, hydraulic cylinder with integral holding valve with Integral pressure transducers provides elevation from -10° to 78°.

### Rated Capacity Limiting (RCL) and anti-two block (ATB) systems

Graphical Display Capacity Limiter and anti-two block system with audio visual warning and crane function lockout. Includes 109 mm (4.3 in), color screen for real-time display of boom angle, length, radius, tip height, maximum permissible load, load indication and warning of impending overload or anti-two-block condition. Work Area Definition System (WADS) allowing operator definable non-lockout warning limits for crane operations and CAN bus sensors and hard-wired ATB circuit routed internally to the boom.

### Operator station

Dual-station ASME B30.5 compliant proportional crane controls with mechanical direct-to-valve control of hoist, lift, telescope and swing functions on both the driver and passenger sides of the crane. Electric over hydraulic control of all outrigger functions using a tethered pendant control for optimum setup visibility. ISO symbols for crane and outrigger functions. RCL display mounted to a rotating arm allowing for easy viewing from either station. Sealed electric switches for control of engine start/stop, 2-speed hoist selection and horn. Electronic throttle pedal located at each side. Load chart binder with tear-proof paper charts.

### Slewing

One (1) planetary slewing gear with a low speed high torque motor with integrated holding valves and spring applied, pressure released brake release circuit. 410°, non-continuous rotation and Manually adjustable swing speed needle valve.

### Hydraulic system

Efficient closed-center, load sense hydraulics system featuring load sharing technology allowing for smooth multifunction operation of all crane functions. One (1) SAE-C mounted, 75cc axial piston pump for all functions and optimized system performance. Shaft input of 2400 RPM generating 47 gpm (178 lpm) max flow at 262 bar (3800 psi) max operating pressure. Radio remote ready allowing for easy upgrade. 276 L (73 gal) hydraulic reservoir with SAE o-ring connections and integrated butterfly shut-off valve for easy maintenance. SAE o-ring hydraulic fittings and hoses.

### Crane Control System

Fully integrated RCL and CAN bus crane control system for maximum performance. Real-time diagnostics for truck chassis data such as engine regeneration, fuel level, engine coolant, oil pressure, engine RPM and battery voltage. On-board setup and diagnostics for all sensors and control modules allowing for improved service and little need for a laptop or diagnostic cables. Fault codes to quickly identify service needs and event recorder to protect your investment. Automotive grade, fully wire harnessed 12VDC electrical system using state of the art sealed connectors and control modules.

## Lower

### Chassis Mounting

Torsion resistant chassis with high-strength steel sub frame. Crane frame and sub frame attached using threaded mounting studs and clamp plates for secure attachment to the truck chassis. Rear outriggers attached using Huck fasteners to both the truck frame and sub frame to ensure a secure and maintenance-free connection. Rear bumper under ride protection standard on factory-mounted cranes. Removable rear mounted boom rest fabricated from structural steel.

### Outriggers

Outrigger monitoring system for beam extension standard with Inverted cylinder rods for outrigger jack cylinders to best protection of chromed rod.

**Front:** Out and down style with individual control of each beam extension and vertical jack cylinder.

Full-span: 6,1 m (20 ft)

Mid-span: 4,27 m (14 ft)

Retracted-span: 2,9 m (7.5 ft)

**Rear:** Out and down style with individual control of each beam extension and vertical jack cylinder.

Full-span: 5,64 m (18.5 ft)

Mid-span: 4,05 m (13.3 ft)

Retracted-span: 2,2 m (7.2 ft)

# Specifications

## Optional items

- **Subframe and Flatbed**
  - > 6,1 m (20 ft) and 6,7 m (22 ft)\* sub frame length options.  
*\*Required for 33,5 m (110 ft) boom, optional for the 30,4 m (100 ft) boom.*
  - > Wood, super-duty wood, steel and super-duty steel beds
- **Hook blocks**
  - > Single sheave, 11,3 t (12.5 USt) quick-reeve hook block for 2-3 part reeving
  - > Triple sheave, 27,2 t (30 USt) quick-reeve hook block for 4-6 part reeving
  - > Triple sheave, 27,2 t (30 USt) quick-reeve hook block for 4-7 part reeving including auxiliary sheave case assembly
- **Jib**
  - > 7,6 m - 13,4 m (25 ft - 44 ft) telescoping boom extension (side fold for stowing), includes 5,8 m (19 ft) manual pull out section
  - > Max tip height with 30,4 m (100 ft) boom is 46,6 m (153 ft)
  - > Max tip height with 33,5 m (110 ft) boom is 49,7 m (163 ft)
  - > RCL calibration for future jib option
- **Hydraulics**
  - > Oil cooler option for duty-cycle operation for demanding applications
  - > 1-option control circuit: 56,8 lpm (15 gpm) at 172 bar (2500 PSI)
- **Operator Aids**
  - > 4-function wireless radio remote control of approximately 75 m (250 ft) (NB4R)
  - > Metric capacity charts
  - > Spanish, Brazilian Portuguese, French documentation and decals
- **Personnel Platforms**
  - > (2) person steel, non-insulated, basket options
  - > Gravity hung, rotating, and yoke-style options
  - > Capacities up to 544,3 kg (1200 lb) on main boom and 226,7 kg (600 lb) on jib
  - > Basket test weight sets available for each
  - > BSA-1, BSA-R1 (provides rotation), BSAY-2
- **Single Front Outrigger**
  - > 63,5 m (25 in) vertical stroke
  - > Required for 360° operation
- **Bulkhead**
  - > Steel 762 mm (30 in) solid wall bulkhead
- **Outrigger float pads**
  - > 24 in diameter aluminum outrigger pads

# Symbols glossary



Axles



Drive



Heavy duty jib



Radius



Boom



Electrical system



Hoist



Rotation



Boom elevation



Engine



Hookblock



Speed



Boom extension



Extension



Hydraulic system



Steering



Boom length



Frame



Insert



Suspension



Boom nose



Fuel tank capacity



Lights



Swing



Brakes



Gear



Oil



Tires



Operators station



Grade



Outrigger controls



Transmission



Counterweight



Height (no max)



Outriggers

# Notes

# The Manitowoc Company, Inc.

## Regional headquarters

### Americas

Milwaukee, Wisconsin, USA

Tel: +1 414 760 4600

Shady Grove, Pennsylvania, USA

Tel: +1 717 597 8121

### Europe and Africa

Dardilly, France - TOWERS

Tel: +33 (0) 4 72 18 20 20

Wilhelmshaven, Germany - MOBILE

Tel: +49 (0) 4421 294 0

### APAC

Shanghai, China

Tel: +86 21 6457 0066

Singapore

Tel: +65 6264 1188

### Middle East and India

Dubai, UAE

Tel: +971 4 8862677

This document is non-contractual. Constant improvement and engineering progress make it necessary that we reserve the right to make specification, equipment, and price changes without notice. Illustrations shown may include optional equipment and accessories and may not include all standard equipment.

