

GROVE®

GRT9165

Product Guide

ASME B30.5 Imperial 85%, Metric 85%



165 USt
(150 t)



44.9 ft - 205 ft
(13,7 m - 62,5 m)



191,795 lb
(86 997 kg)



299 ft
(91,1 m)



GROVE GRT9165

FEATURES

The GRT9165 was designed after gathering feedback from crane owners and operators to ensure it's loaded with the features and reliability you demand. With a class-leading 205 ft (62,5 m) main boom, new wider full vision cab, intuitive Crane Control System (CCS), reduced transport height and best in class load charts, the GRT9165 will be a valuable asset in any crane owners' fleet.

Superior strength and reach

Class-leading lifting performance is enhanced by the 13,7 m to 62,5 m (44.9 ft to 205 ft) six-section MEGAFORM™ boom with TWIN-LOCK™ boom pinning system. The MEGAFORM™ boom design provides exceptional strength-to-weight ratio. Boosting overall reach is the 17,8 m (58.4 ft) manual or hydraulic swingaway jib, which can be further extended by adding an 8 m (26.2 ft) lattice insert for a total extension length of 25,8 m (84.6 ft). Either swingaway jib can be offset up to 50°, which is unmatched in its class and provides additional reach and versatility.



Full Vision Cab

The GRT9165's cab was designed with operator comfort, visibility and productivity in mind. Additional width, redesigned armrests and 20° cab tilt maximize the operator experience. Standard features include tilt/telescoping steering wheel, USB charging port, electronic seat adjustments, high-output heating and air conditioning system, large pivoting cup holder, windshield sun visor, added storage behind the seat, and three camera package. Additional optional equipment includes radio with Bluetooth and heated seat.



GROVE.
RREAL.
TOUGH.

Backing Up Our Promise

Our GRT line of Rough Terrain cranes have been designed from the ground up to provide class-leading specifications, and have undergone extensive testing to ensure they provide industry-leading quality and reliability. We stand behind our new line of GRT cranes, and we are willing to prove it. With new three, four or five-year extended warranty programs as well as a new two-year standard warranty, our GRT line of cranes are built to be **GROVE. REAL. TOUGH.**

Innovative control system

The Crane Control System (CCS) offers a user-friendly interface, two full graphic displays mounted independently for easy adjustment and an arm rest jog dial for convenient navigation and data input. The system allows the electronic controllers to be programmed by the operator for specific speed and reaction. Parts commonality across Grove, Manitowoc and Potain product lines enhances operator familiarization and serviceability. Additional features include ECO mode, Working Range Limiter (WRL) and Boom Configurator telescoping mode.



The world's most advanced crane service and support network

WORLDWIDE SUPPORT NETWORK

Manitowoc's customer service extends beyond any borders. Our locations span the globe, covering five continents. No matter where the job takes you, you have a business partner nearby.



PARTS

Locating the correct part quickly is vital to managing your operations. With Manitowoc Customer Support, the parts you need are just a phone call or click away.

LIFT SOLUTIONS

The Manitowoc Crane Lift Solutions Team is dedicated to helping customers with unique and customized applications for their Manitowoc cranes, regardless of product line.

TRAINING

Manitowoc Training Centers offer courses for operators and technicians across the globe to provide in-depth instruction on crane operation, maintenance, and troubleshooting procedures.

EnCORE

Manitowoc's EnCORE program maximizes your investment by rebuilding or repairing your crane to extend its life significantly. EnCORE also includes remanufactured parts.



MANITOWOC FINANCE

Manitowoc Finance gets you in the field with the right equipment by giving you access to flexible, affordable financing. With Manitowoc Finance, equipment can be acquired with virtually no cash outlay, and unlike traditional lending, our financial products don't affect bank lines of credit. Your capital resources remain intact for times when you need ready access to cash.

Competitive rates with flexible financing options and payment schedules put you in control.

Did you know? Manitowoc Finance can finance **used** Manitowoc cranes. You can also **trade-in** your used fleet for upgrade and get financed by Manitowoc Finance.





CONTENTS

8

Dimensions and Weights

10

Working Range Diagram with Bi-Fold Extension

11

Load Chart - Main Boom

12

Load Charts - Manual Bi-Fold Extension

14

Load Charts - Hydraulic Bi-Fold Extension

16

Working Range Diagram with Bi-Fold Extension and Insert

17

Load Chart - Insert and Manual Bi-Fold Extension

18

Load Chart - Insert and Hydraulic Bi-Fold Extension

19

Working Range Diagram with Heavy Duty Jib

20

Load Chart - Heavy Duty Jib

21

Load Chart - Pick and Carry

22

Rigging Charts

23

Load Handling

24

Specifications

DIMENSIONS & WEIGHTS

Tire size: 26.5 x 25

A	B	C	D	E	F	G	A	B	C	D	E	F	G
19,7 m (64' 8")	19,0 m (62' 4")	16,4 m (53' 10")	15,6 m (51' 2")	15,2 m (49' 10")	12,5 m (41' 0")	11,2 m (36' 9")	15,0 m (49' 3")	14,4 m (47' 3")	11,3 m (37' 1")	10,6 m (34' 9")	10,2 m (33' 6")	7,4 m (24' 3")	6,5 m (21' 4")
Two-wheel steer							Six-wheel steer						

Dimensions in mm (in) unless otherwise specified.

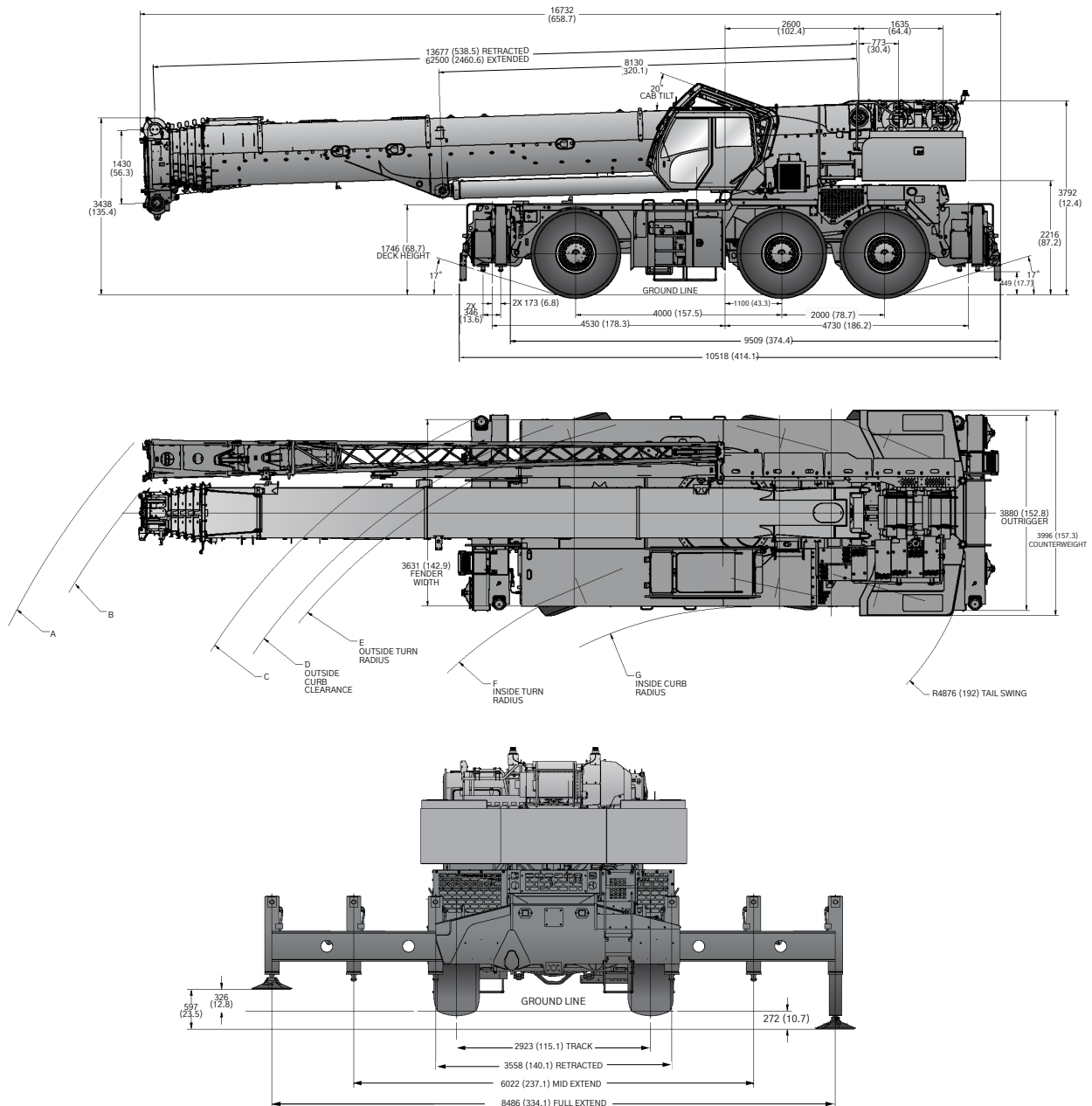

DIMENSIONS & WEIGHTS

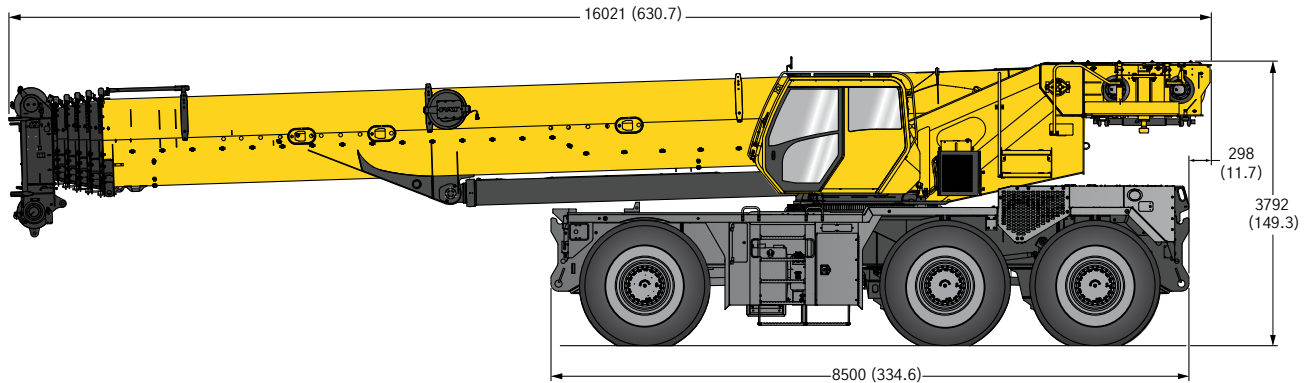

TRANSPORT DIMENSIONS
OUTRIGGER BOXES AND COUNTERWEIGHT REMOVED

Weights	GVW		Front		Rear	
	kg	lb	kg	lb	kg	lb
Basic crane with Cummins T4F/Stage V engine, 62,5 m (205 ft) main boom, main and auxiliary hoist with wire rope, 17,8 m (58.4 ft) manually offset bi-fold swingaway, 100 t (112 USt) hook block, 11 t (12 USt) overhaul weight, auxiliary boom nose, front and rear outrigger box installed and 25,764 kg (56 800 lb) counterweight	86,996	191,793	29,169	64,307	57,827	127,486
Substitute 11,2 m – 17,8 m (36.7 ft – 58.4 ft) hydraulically offset bi-fold swingaway and stowage brackets ILO standard manual bi-fold swingaway	296	653	615	1,355	-318	-702
Remove 18 799 kg (41,400 lb) counterweight base and two 3485 kg (7700 lb) counterweight inserts	-25,764	-56,800	8,484	18,703	-34,248	-75,503
Remove front outrigger box	-3,955	-8,720	-5,245	-11,563	1,290	2,843
Remove rear outrigger box	-3,955	-8,720	2,081	4,587	-6,036	-13,307
Remove auxiliary boom nose	-195	-430	-534	-1,177	339	747
Remove 17,8 m (58.4 ft) manual offset bi-fold swingaway	-1,658	-3,655	-2,786	-6,142	1,128	2,487
Remove 11 t (12 USt) overhaul weight	-380	-838	-599	-1,320	219	482
Remove 100 t (112 USt) hook block	-1,140	-2,513	-1,071	-2,362	-68	-151
Remove 62,5 m (205 ft) main boom and manually offsettable swingaway extension brackets	-15,816	-34,868	-19,340	-42,637	3,524	7,769

WORKING RANGE

Working Range Diagram with Bi-Fold Extension

(Boom deflection not shown)

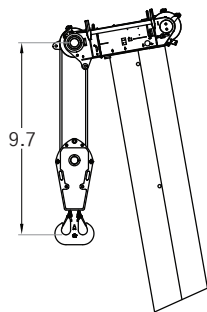
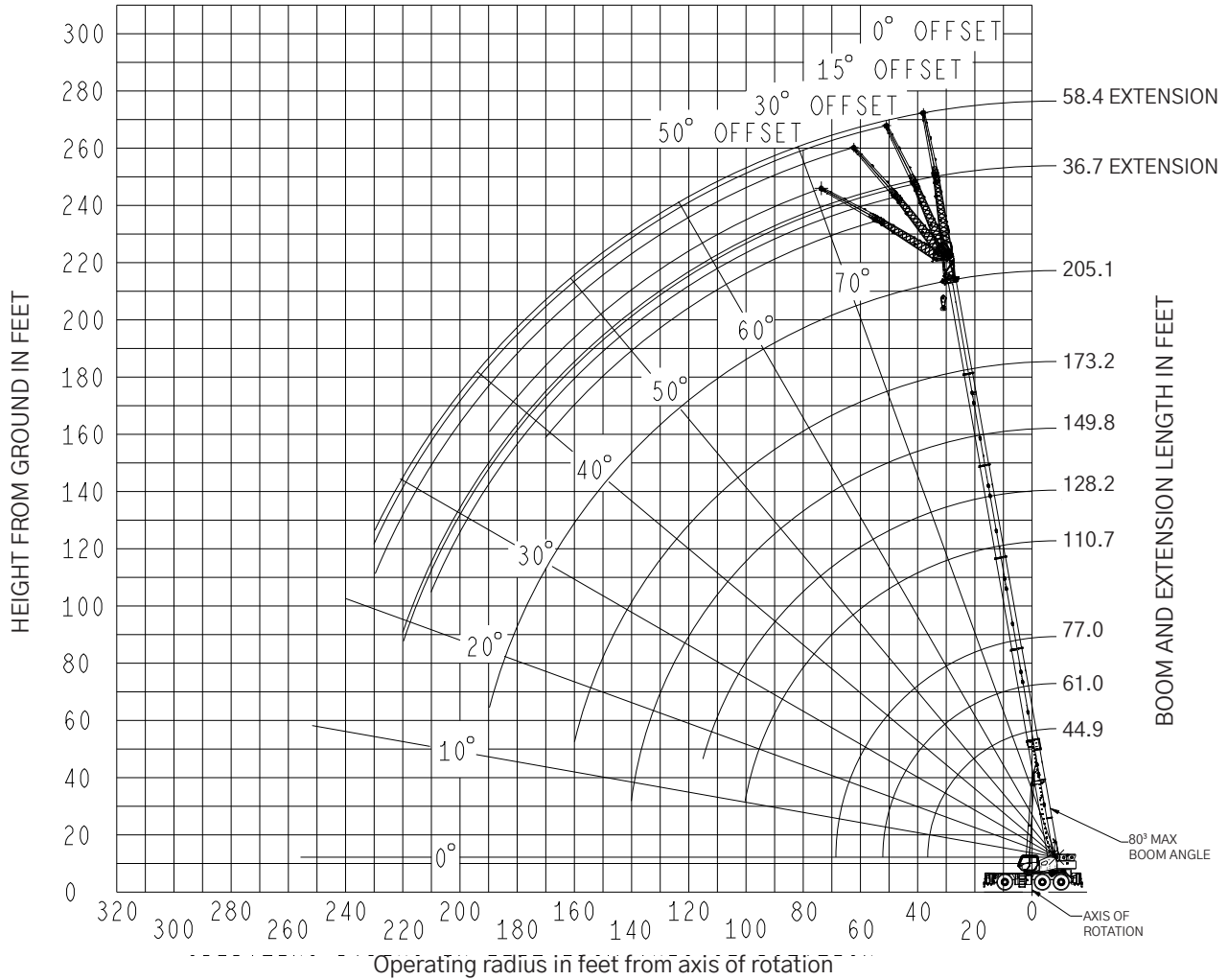

Dimensions are for the largest Grove furnished hook block, with anti-two block activated.

THIS CHART IS ONLY A GUIDE AND SHOULD NOT BE USED TO OPERATE THE CRANE.
The individual crane's load chart, operating instructions and other instructional plates must be read and understood prior to operating the crane

LOAD CHART

Main Boom



44.9 ft – 205.1 ft



56,800 lb



100%



360°



Pounds

Radius in feet	Main boom length in feet											
	44.9	60.9 – 62.4	73.5 – 79.9	89.5 – 96.1	102 – 112.1	125.2 – 130.7	148.3 – 153.2	158.9 – 162.4	165.8 – 174.9	176.6 – 187.4	198	205.1
8	330,000*											
9	235,000											
10	228,000	201,000										
12	217,000	187,500	168,000									
15	198,000	172,000	158,500	121,000								
20	163,500	158,500	139,500	128,000	103,000							
25	136,500	136,500	125,000	114,500	103,000	80,300						
30	111,000	117,500	113,000	105,000	98,650	80,300	54,550					
35	76,850	99,950	98,050	98,250	91,200	80,300	54,550	45,300	41,100			
40		85,550	86,100	85,300	85,650	76,650	54,550	45,300	41,100	35,200		
45		74,000	73,350	71,650	73,450	70,600	54,550	45,300	40,950	35,200	26,300	23,950
50		57,200	61,650	63,150	61,500	63,350	51,750	45,300	38,250	35,200	26,300	23,950
55			54,350	53,850	53,750	54,000	48,000	44,250	36,400	35,200	26,300	23,950
60			47,000	46,700	48,550	46,950	44,400	41,400	36,400	34,000	26,300	23,950
65			41,000	42,400	42,650	41,100	39,950	38,800	34,700	31,900	26,300	23,950
70			26,800	38,450	37,800	36,250	35,150	36,100	32,600	30,600	26,000	23,950
75				34,350	33,850	32,400	31,350	32,300	30,500	28,900	24,450	23,950
80				30,900	30,350	29,000	28,550	28,850	28,600	27,200	23,050	23,450
85				22,300	27,300	26,050	27,100	25,900	25,800	25,600	21,750	22,200
90					24,700	23,450	24,950	23,350	23,250	24,000	20,600	21,050
95					22,500	21,200	22,700	21,150	21,800	21,750	19,500	19,950
100					19,000	19,150	20,700	19,150	20,700	20,400	18,550	18,950
105						17,400	18,950	17,400	19,000	18,700	17,600	18,000
110						15,850	17,300	16,050	17,400	17,150	16,750	16,700
115						14,400	16,000	15,150	16,150	15,900	15,500	15,250
120						12,750	15,100	14,300	14,800	14,600	14,200	13,950
125							14,400	13,500	13,600	13,400	13,050	12,800
130							13,600	12,750	12,500	12,300	11,950	11,700
135							12,550	12,050	11,500	11,300	11,000	10,750
140							10,450	11,200	10,550	10,350	10,050	9,840
145								10,350	9,740	9,530	9,230	9,000
150								7,430	8,950	8,740	8,440	8,200
155									8,090	8,010	7,700	7,470
160									7,610	7,330	7,020	6,780
165									2,620	6,120	6,380	6,140
170										5,460	5,780	5,550
175										4,870	5,230	4,990
180											4,710	4,470
185											4,230	3,980
190												3,530

*Requires special equipment

THIS CHART IS ONLY A GUIDE AND SHOULD NOT BE USED TO OPERATE THE CRANE.

The individual crane's load chart, operating instructions and other instructional plates must be read and understood prior to operating the crane

LOAD CHART

Manual Bi-Fold Extension



44.9 ft – 205.1 ft



37 ft



56,800 lb



100%



360°



Pounds

Radius in feet	37 ft boom extension															
	176.6 ft boom length				187.4 ft boom length				198 ft boom length				205.1 ft boom length			
	0° offset	15° offset	30° offset	50° offset	0° offset	15° offset	30° offset	50° offset	0° offset	15° offset	30° offset	50° offset	0° offset	15° offset	30° offset	50° offset
45	19,600				17,550											
50	19,600				17,550				15,000				13,750			
55	19,600	19,950			17,550	17,650			15,000				13,750			
60	19,600	19,950	20,050		17,550	17,650			15,000	15,150			13,750	13,900		
65	19,600	19,950	20,050	20,950	17,550	17,650	17,800		15,000	15,150			13,750	13,900		
70	19,600	19,950	20,050	20,950	17,550	17,650	17,800	18,450	15,000	15,150	15,050		13,750	13,900	13,700	
75	19,600	19,950	20,050	20,300	17,550	17,650	17,800	18,450	15,000	15,150	15,050	15,450	13,750	13,900	13,700	14,000
80	19,600	19,950	19,550	19,500	17,550	17,650	17,800	18,450	15,000	15,150	15,050	15,450	13,750	13,900	13,700	14,000
85	19,600	19,300	18,750	18,700	17,550	17,650	17,800	18,450	15,000	15,150	15,050	15,450	13,750	13,900	13,700	14,000
90	18,700	18,400	17,950	17,950	17,550	17,650	17,800	18,200	15,000	15,150	15,050	15,450	13,750	13,900	13,700	14,000
95	17,750	17,450	17,200	17,250	17,550	17,650	17,550	17,550	15,000	14,950	14,950	15,250	13,750	13,900	13,700	14,000
100	16,800	16,600	16,500	16,550	17,350	17,100	16,850	16,900	14,350	14,150	14,150	14,450	13,750	13,900	13,700	14,000
105	15,950	15,750	15,750	15,950	16,500	16,300	16,200	16,300	13,550	13,400	13,400	13,700	13,750	13,650	13,650	13,900
110	15,150	15,000	15,000	15,350	15,700	15,500	15,500	15,700	12,800	12,700	12,750	13,000	13,100	12,950	12,950	13,250
115	14,400	14,300	14,300	14,600	14,850	14,800	14,800	15,100	12,100	12,050	12,100	12,350	12,400	12,300	12,350	12,600
120	13,700	13,600	13,650	13,950	13,550	14,150	14,150	14,450	11,500	11,450	11,500	11,750	11,750	11,700	11,750	12,000
125	12,900	13,000	13,050	13,300	12,350	12,950	13,400	13,700	10,900	10,850	10,900	11,150	11,200	11,100	11,150	11,400
130	12,000	12,400	12,450	12,700	11,300	11,850	12,250	12,500	10,350	10,300	10,400	10,600	10,600	10,600	10,650	10,850
135	11,000	11,500	11,800	12,000	10,300	10,800	11,200	11,400	9,830	9,830	9,900	10,100	10,100	10,050	10,150	10,350
140	10,100	10,550	10,850	10,950	9,420	9,890	10,200	10,400	9,330	9,350	9,420	9,630	9,250	9,620	9,680	9,900
145	9,290	9,680	9,950	10,050	8,580	9,020	9,330	9,480	8,710	8,890	8,970	9,170	8,420	8,890	9,230	9,440
150	8,510	8,870	9,110		7,810	8,210	8,490	8,610	7,940	8,360	8,540	8,730	7,640	8,090	8,410	8,590
155	7,790	8,120	8,320		7,090	7,460	7,710	7,790	7,220	7,610	7,880	8,000	6,930	7,340	7,630	7,780
160	7,120	7,420	7,590		6,420	6,760	6,980		6,550	6,910	7,160	7,250	6,260	6,640	6,910	7,030
165	6,500	6,760	6,910		5,800	6,110	6,300		5,920	6,260	6,480		5,630	5,990	6,230	6,320
170	5,920	6,150	6,270		5,210	5,500	5,660		5,340	5,650	5,840		5,050	5,380	5,600	5,650
175	5,370	5,580	5,670		4,670	4,930	5,060		4,790	5,080	5,250		4,500	4,810	5,000	
180	4,860	5,040	5,100		4,160	4,390	4,500		4,280	4,540	4,680		3,990	4,270	4,440	
185	4,390	4,530	4,560		3,680	3,880	3,970		3,800	4,030	4,150		3,510	3,770	3,910	
190	3,940	4,060			3,230	3,410	3,460		3,350	3,560	3,650		3,060	3,290	3,410	
195	3,530	3,610			2,810	2,960	2,980		2,920	3,110	3,180		2,630	2,840	2,940	
200	2,860	3,090			2,420	2,530			2,520	2,680	2,730		2,230	2,420	2,490	
205					2,050	2,130			2,150	2,280	2,300		1,850	2,010	2,060	
210					1,690	1,750			1,790	1,900			1,490	1,630	1,660	
215									1,460	1,540			1,160	1,270		
220									1,160	1,190						

THIS CHART IS ONLY A GUIDE AND SHOULD NOT BE USED TO OPERATE THE CRANE.

The individual crane's load chart, operating instructions and other instructional plates must be read and understood prior to operating the crane

LOAD CHART

Manual Bi-Fold Extension



44.9 ft – 205.1 ft



59 ft



56,800 lb



100%



360°



Pounds

Radius in feet	59 ft boom extension															
	176.6 ft boom length				187.4 ft boom length				198 ft boom length				205.1 ft boom length			
	0° offset	15° offset	30° offset	50° offset	0° offset	15° offset	30° offset	50° offset	0° offset	15° offset	30° offset	50° offset	0° offset	15° offset	30° offset	50° offset
50	12,600				11,600				10,200							
55	12,600				11,600				10,200				9,530			
60	12,600				11,600				10,200				9,530			
65	12,600	13,400			11,600	12,200			10,200				9,530			
70	12,600	13,400			11,600	12,200			10,200				9,530			
75	12,600	13,400			11,600	12,200			10,200	10,750			9,530	9,990		
80	12,600	13,400	12,250		11,600	12,200			10,200	10,750			9,530	9,990		
85	12,600	13,200	12,100	10,850	11,600	12,200	12,050		10,200	10,750			9,530	9,990		
90	12,600	13,050	11,950	10,750	11,600	12,200	11,900		10,200	10,750	11,550		9,530	9,990	10,650	
95	12,600	12,900	11,850	10,650	11,600	12,200	11,800	10,700	10,200	10,750	11,550	10,650	9,530	9,990	10,650	
100	12,600	12,700	11,750	10,600	11,600	12,200	11,700	10,600	10,200	10,750	11,500	10,600	9,530	9,990	10,650	10,600
105	12,600	12,550	11,600	10,550	11,600	12,200	11,600	10,550	10,200	10,750	11,400	10,550	9,530	9,990	10,650	10,550
110	12,600	12,400	11,400	10,500	11,600	12,200	11,500	10,500	10,200	10,750	11,350	10,500	9,530	9,990	10,650	10,500
115	12,600	12,250	11,250	10,450	11,600	12,200	11,350	10,450	10,200	10,750	11,250	10,450	9,530	9,990	10,650	10,450
120	12,450	12,050	11,150	10,400	11,600	12,050	11,200	10,400	10,200	10,550	10,700	10,400	9,530	9,990	10,650	10,400
125	11,900	11,600	11,000	10,400	11,600	11,900	11,050	10,400	10,000	10,000	10,200	10,350	9,530	9,990	10,350	10,350
130	11,350	11,150	10,900	10,350	11,600	11,450	10,950	10,350	9,490	9,540	9,710	10,200	9,530	9,720	9,870	10,350
135	10,800	10,750	10,650	10,350	11,000	11,050	10,850	10,350	9,010	9,070	9,250	9,720	9,230	9,260	9,420	9,890
140	10,300	10,350	10,300	10,350	10,100	10,700	10,550	10,350	8,560	8,630	8,810	9,250	8,780	8,820	8,990	9,430
145	9,880	9,940	9,990	10,250	9,260	10,050	10,250	10,350	8,130	8,220	8,400	8,810	8,350	8,410	8,570	9,000
150	9,180	9,510	9,660	9,930	8,470	9,240	9,860	10,200	7,730	7,820	8,000	8,390	7,950	8,020	8,180	8,580
155	8,450	9,100	9,280	9,630	7,750	8,470	9,040	9,430	7,340	7,450	7,620	7,990	7,510	7,650	7,810	8,180
160	7,770	8,380	8,840	9,100	7,070	7,750	8,270	8,610	6,980	7,090	7,260	7,600	6,830	7,290	7,450	7,810
165	7,140	7,700	8,120	8,320	6,440	7,080	7,550	7,840	6,500	6,750	6,920	7,240	6,200	6,890	7,110	7,440
170	6,540	7,070	7,440	7,590	5,850	6,450	6,880	7,110	5,910	6,430	6,590	6,880	5,610	6,260	6,760	7,080
175	5,990	6,480	6,810		5,300	5,850	6,250	6,420	5,360	5,940	6,280	6,550	5,060	5,670	6,130	6,410
180	5,470	5,920	6,210		4,780	5,290	5,650		4,840	5,380	5,780	5,960	4,540	5,120	5,540	5,770
185	4,990	5,390	5,640		4,300	4,770	5,090		4,350	4,860	5,210	5,350	4,050	4,590	4,980	5,160
190	4,530	4,890	5,100		3,840	4,270	4,550		3,890	4,360	4,680		3,600	4,100	4,450	4,590
195	4,100	4,420	4,590		3,410	3,800	4,040		3,460	3,890	4,180		3,160	3,630	3,950	
200	3,690	3,980	4,100		3,000	3,360	3,560		3,050	3,450	3,700		2,750	3,190	3,470	
205	3,310	3,550	3,640		2,620	2,940	3,100		2,670	3,030	3,250		2,370	2,770	3,020	
210	2,950	3,150			2,260	2,540	2,660		2,300	2,630	2,810		2,000	2,370	2,590	
215	2,620	2,770			1,920	2,160	2,230		1,960	2,250	2,400		1,660	1,990	2,180	
220	2,310	2,400			1,600	1,790			1,630	1,890	2,000		1,330	1,630	1,780	
225					1,290	1,450			1,320	1,550	1,620		1,020	1,290	1,400	
230					1,010	1,110			1,030	1,220					1,040	

THIS CHART IS ONLY A GUIDE AND SHOULD NOT BE USED TO OPERATE THE CRANE.

The individual crane's load chart, operating instructions and other instructional plates must be read and understood prior to operating the crane

LOAD CHART

Hydraulic Bi-Fold Extension



44.9 ft – 205.1 ft



37 ft



56,800 lb



100%



360°



Pounds

Radius in feet	37 ft boom extension															
	176.6 ft boom length				187.4 ft boom length				198 ft boom length				205.1 ft boom length			
	0° offset	0° – 15° offset	15° – 30° offset	30° – 50° offset	0° offset	0° – 15° offset	15° – 30° offset	30° – 50° offset	0° offset	0° – 15° offset	15° – 30° offset	30° – 50° offset	0° offset	0° – 15° offset	15° – 30° offset	30° – 50° offset
45	19,600				17,550											
50	19,600				17,550				15,000				13,750			
55	19,600	19,600			17,550	17,550			15,000				13,750			
60	19,600	19,600	19,950		17,550	17,550			15,000	15,000			13,750	13,750		
65	19,600	19,600	19,950	20,050	17,550	17,550	17,650		15,000	15,000			13,750	13,750		
70	19,600	19,600	19,950	20,050	17,550	17,550	17,650	17,800	15,000	15,000	15,050		13,750	13,750	13,700	
75	19,600	19,600	19,950	20,050	17,550	17,550	17,650	17,800	15,000	15,000	15,050	15,050	13,750	13,750	13,700	13,700
80	19,600	19,600	19,550	19,500	17,550	17,550	17,650	17,800	15,000	15,000	15,050	15,050	13,750	13,750	13,700	13,700
85	19,600	19,300	18,750	18,700	17,550	17,550	17,650	17,800	15,000	15,000	15,050	15,050	13,750	13,750	13,700	13,700
90	18,700	18,400	17,950	17,950	17,550	17,550	17,650	17,800	15,000	15,000	15,050	15,050	13,750	13,750	13,700	13,700
95	17,750	17,450	17,200	17,200	17,550	17,550	17,550	17,550	15,000	14,950	14,950	14,950	13,750	13,750	13,700	13,700
100	16,800	16,600	16,500	16,500	17,350	17,100	16,850	16,850	14,350	14,150	14,150	14,150	13,750	13,750	13,700	13,700
105	15,950	15,750	15,750	15,750	16,500	16,300	16,200	16,200	13,550	13,400	13,400	13,400	13,750	13,650	13,650	13,650
110	15,150	15,000	15,000	15,000	15,700	15,500	15,500	15,500	12,800	12,700	12,700	12,750	13,100	12,950	12,950	12,950
115	14,400	14,300	14,300	14,300	14,850	14,800	14,800	14,800	12,100	12,050	12,050	12,100	12,400	12,300	12,300	12,350
120	13,700	13,600	13,600	13,650	13,550	13,550	14,150	14,150	11,500	11,450	11,450	11,500	11,750	11,700	11,700	11,750
125	12,900	12,900	13,000	13,050	12,350	12,350	12,950	13,400	10,900	10,850	10,850	10,900	11,200	11,100	11,100	11,150
130	12,000	12,000	12,400	12,450	11,300	11,300	11,850	12,250	10,350	10,300	10,300	10,400	10,600	10,600	10,600	10,650
135	11,000	11,000	11,500	11,800	10,300	10,300	10,800	11,200	9,830	9,830	9,830	9,900	10,100	10,050	10,050	10,150
140	10,100	10,100	10,550	10,850	9,420	9,420	9,890	10,200	9,330	9,330	9,350	9,420	9,250	9,250	9,620	9,680
145	9,290	9,290	9,680	9,950	8,580	8,580	9,020	9,330	8,710	8,710	8,890	8,970	8,420	8,420	8,890	9,230
150	8,510	8,510	8,870		7,810	7,810	8,210	8,490	7,940	7,940	8,360	8,540	7,640	7,640	8,090	8,410
155	7,790	7,790	8,120		7,090	7,090	7,460	7,710	7,220	7,220	7,610	7,880	6,930	6,930	7,340	7,630
160	7,120	7,120	7,420		6,420	6,420	6,760		6,550	6,550	6,910	7,160	6,260	6,260	6,640	6,910
165	6,500	6,500	6,760		5,800	5,800	6,110		5,920	5,920	6,260		5,630	5,630	5,990	6,230
170	5,920	5,920	6,150		5,210	5,210	5,500		5,340	5,340	5,650		5,050	5,050	5,380	5,600
175	5,370	5,370	5,580		4,670	4,670	4,930		4,790	4,790	5,080		4,500	4,500	4,810	
180	4,860	4,860	5,040		4,160	4,160	4,390		4,280	4,280	4,540		3,990	3,990	4,270	
185	4,390	4,390	4,530		3,680	3,680	3,880		3,800	3,800	4,030		3,510	3,510	3,770	
190	3,940	3,940			3,230	3,230	3,410		3,350	3,350	3,560		3,060	3,060	3,290	
195	3,530	3,530			2,810	2,810	2,960		2,920	2,920	3,110		2,630	2,630	2,840	
200	2,860	2,860			2,420	2,420			2,520	2,520	2,680		2,230	2,230	2,420	
205					2,050	2,050			2,150	2,150	2,280		1,850	1,850	2,010	
210					1,690	1,690			1,790	1,790			1,490	1,490	1,630	
215									1,460	1,460			1,160	1,160		
220									1,160	1,160						

THIS CHART IS ONLY A GUIDE AND SHOULD NOT BE USED TO OPERATE THE CRANE.

The individual crane's load chart, operating instructions and other instructional plates must be read and understood prior to operating the crane

LOAD CHART

Hydraulic Bi-Fold Extension



44.9 ft – 205.1 ft



59 ft



56,800 lb



100%



360°



Pounds

Radius in feet	59 ft boom extension															
	176.6 ft boom length				187.4 ft boom length				198 ft boom length				205.1 ft boom length			
	0° offset	0° – 15° offset	15° – 30° offset	30° – 50° offset	0° offset	0° – 15° offset	15° – 30° offset	30° – 50° offset	0° offset	0° – 15° offset	15° – 30° offset	30° – 50° offset	0° offset	0° – 15° offset	15° – 30° offset	30° – 50° offset
50	12,600				11,600				10,200							
55	12,600				11,600				10,200				9,530			
60	12,600				11,600				10,200				9,530			
65	12,600	12,600			11,600	11,600			10,200				9,530			
70	12,600	12,600			11,600	11,600			10,200				9,530			
75	12,600	12,600			11,600	11,600			10,200	10,200			9,530	9,530		
80	12,600	12,600	12,250		11,600	11,600			10,200	10,200			9,530	9,530		
85	12,600	12,600	12,100	10,850	11,600	11,600	12,050		10,200	10,200			9,530	9,530		
90	12,600	12,600	11,950	10,750	11,600	11,600	11,900		10,200	10,200	10,750		9,530	9,530	9,990	
95	12,600	12,600	11,850	10,650	11,600	11,600	11,800	10,700	10,200	10,200	10,750	10,650	9,530	9,530	9,990	
100	12,600	12,600	11,750	10,600	11,600	11,600	11,700	10,600	10,200	10,200	10,750	10,600	9,530	9,530	9,990	10,600
105	12,600	12,550	11,600	10,550	11,600	11,600	11,600	10,550	10,200	10,200	10,750	10,550	9,530	9,530	9,990	10,550
110	12,600	12,400	11,400	10,500	11,600	11,600	11,500	10,500	10,200	10,200	10,750	10,500	9,530	9,530	9,990	10,500
115	12,600	12,250	11,250	10,450	11,600	11,600	11,350	10,450	10,200	10,200	10,750	10,450	9,530	9,530	9,990	10,450
120	12,450	12,050	11,150	10,400	11,600	11,600	11,200	10,400	10,200	10,200	10,550	10,400	9,530	9,530	9,990	10,400
125	11,900	11,600	11,000	10,400	11,600	11,600	11,050	10,400	10,000	10,000	10,000	10,200	9,530	9,530	9,990	10,350
130	11,350	11,150	10,900	10,350	11,600	11,450	10,950	10,350	9,490	9,490	9,540	9,710	9,530	9,530	9,720	9,870
135	10,800	10,750	10,650	10,350	11,000	11,000	10,850	10,350	9,010	9,010	9,070	9,250	9,230	9,230	9,260	9,420
140	10,300	10,300	10,300	10,300	10,100	10,100	10,550	10,350	8,560	8,560	8,630	8,810	8,780	8,780	8,820	8,990
145	9,880	9,880	9,940	9,990	9,260	9,260	10,050	10,250	8,130	8,130	8,220	8,400	8,350	8,350	8,410	8,570
150	9,180	9,180	9,510	9,660	8,470	8,470	9,240	9,860	7,730	7,730	7,820	8,000	7,950	7,950	8,020	8,180
155	8,450	8,450	9,100	9,280	7,750	7,750	8,470	9,040	7,340	7,340	7,450	7,620	7,510	7,510	7,650	7,810
160	7,770	7,770	8,380	8,840	7,070	7,070	7,750	8,270	6,980	6,980	7,090	7,260	6,830	6,830	7,290	7,450
165	7,140	7,140	7,700	8,120	6,440	6,440	7,080	7,550	6,500	6,500	6,750	6,920	6,200	6,200	6,890	7,110
170	6,540	6,540	7,070	7,440	5,850	5,850	6,450	6,880	5,910	5,910	6,430	6,590	5,610	5,610	6,260	6,760
175	5,990	5,990	6,480		5,300	5,300	5,850	6,250	5,360	5,360	5,940	6,280	5,060	5,060	5,670	6,130
180	5,470	5,470	5,920		4,780	4,780	5,290		4,840	4,840	5,380	5,780	4,540	4,540	5,120	5,540
185	4,990	4,990	5,390		4,300	4,300	4,770		4,350	4,350	4,860	5,210	4,050	4,050	4,590	4,980
190	4,530	4,530	4,890		3,840	3,840	4,270		3,890	3,890	4,360		3,600	3,600	4,100	4,450
195	4,100	4,100	4,420		3,410	3,410	3,800		3,460	3,460	3,890		3,160	3,160	3,630	
200	3,690	3,690	3,980		3,000	3,000	3,360		3,050	3,050	3,450		2,750	2,750	3,190	
205	3,310	3,310	3,550		2,620	2,620	2,940		2,670	2,670	3,030		2,370	2,370	2,770	
210	2,950	2,950			2,260	2,260	2,540		2,300	2,300	2,630		2,000	2,000	2,370	
215	2,620	2,620			1,920	1,920	2,160		1,960	1,960	2,250		1,660	1,660	1,990	
220	2,310	2,310			1,600	1,600			1,630	1,630	1,890		1,330	1,330	1,630	
225					1,290	1,290			1,320	1,320	1,550		1,020	1,020	1,290	
230					1,010	1,010			1,030	1,030						

THIS CHART IS ONLY A GUIDE AND SHOULD NOT BE USED TO OPERATE THE CRANE.

The individual crane's load chart, operating instructions and other instructional plates must be read and understood prior to operating the crane

WORKING RANGE

Working Range Diagram with Bi-Fold Extension and Insert

(Boom deflection not shown)

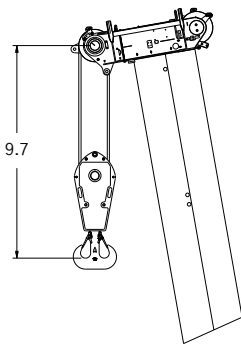
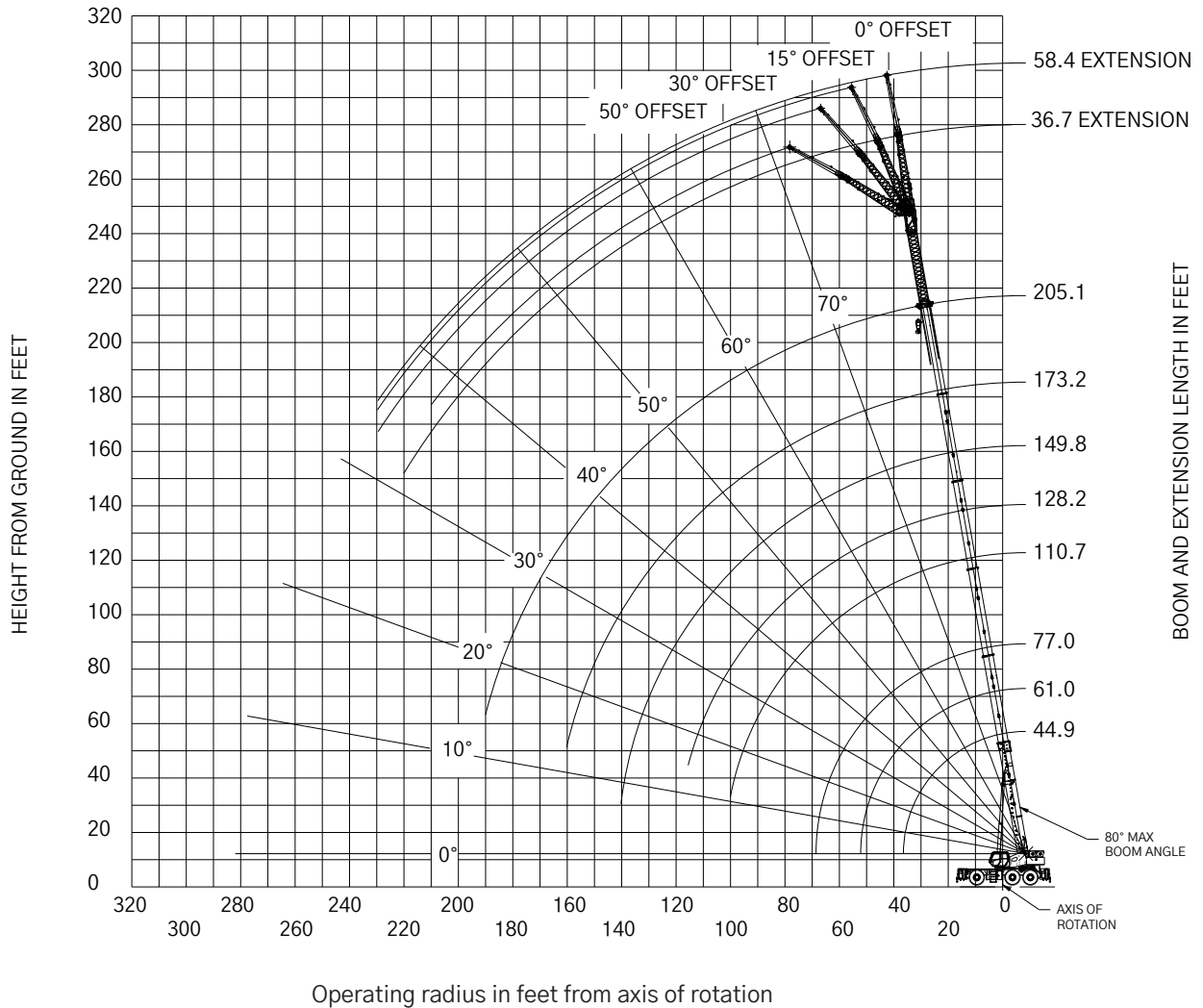

Dimensions are for the largest Grove furnished hook block, with anti-two block activated.

THIS CHART IS ONLY A GUIDE AND SHOULD NOT BE USED TO OPERATE THE CRANE.
The individual crane's load chart, operating instructions and other instructional plates must be read and understood prior to operating the crane

LOAD CHART

Insert and Manual Bi-Fold Extension



44.9 ft – 205.1 ft



85 ft



26 ft



56,800 lb



100%



360°



Pounds

Radius in feet	85 ft boom extension															
	176.6 ft boom length				187.4 ft boom length				198 ft boom length				205.1 ft boom length			
	0° offset	15° offset	30° offset	50° offset	0° offset	15° offset	30° offset	50° offset	0° offset	15° offset	30° offset	50° offset	0° offset	15° offset	30° offset	50° offset
50	8,810															
55	8,810				8,060											
60	8,810				8,060				7,010				6,500			
65	8,810				8,060				7,010				6,500			
70	8,810				8,060				7,010				6,500			
75	8,810	8,800			8,060	8,050			7,010				6,500			
80	8,810	8,800			8,060	8,050			7,010	7,000			6,500	6,740		
85	8,810	8,800	8,840		8,060	8,050			7,010	7,000			6,500	6,740		
90	8,810	8,800	8,840		8,060	8,050	8,080		7,010	7,000			6,500	6,740		
95	8,810	8,800	8,840		8,060	8,050	8,080		7,010	7,000	7,040		6,500	6,740	7,040	
100	8,810	8,800	8,840	8,840	8,060	8,050	8,080	8,080	7,010	7,000	7,040		6,500	6,740	7,040	
105	8,810	8,800	8,840	8,840	8,060	8,050	8,080	8,080	7,010	7,000	7,040	7,040	6,500	6,740	7,040	
110	8,810	8,800	8,840	8,840	8,060	8,050	8,080	8,080	7,010	7,000	7,040	7,040	6,500	6,740	7,040	6,530
115	8,810	8,800	8,840	8,840	8,060	8,050	8,080	8,080	7,010	7,000	7,040	7,040	6,500	6,740	7,040	6,530
120	8,810	8,800	8,840	8,840	8,060	8,050	8,080	8,080	7,010	7,000	7,040	7,040	6,500	6,740	7,040	6,530
125	8,810	8,800	8,840	8,840	8,060	8,050	8,080	8,080	7,010	7,000	7,040	7,040	6,500	6,740	7,040	6,530
130	8,810	8,800	8,840	8,840	8,060	8,050	8,080	8,080	7,010	7,000	7,040	7,040	6,500	6,740	7,040	6,530
135	8,810	8,800	8,640	8,740	8,060	8,050	8,080	8,080	7,010	7,000	7,040	7,040	6,500	6,740	7,040	6,530
140	8,560	8,470	8,370	8,490	8,060	8,050	8,080	8,080	7,010	7,000	7,040	7,040	6,500	6,740	7,040	6,530
145	8,200	8,130	8,110	8,250	8,060	8,050	8,080	8,080	6,810	7,000	7,040	7,040	6,500	6,740	7,040	6,530
150	7,870	7,810	7,870	8,030	8,060	8,040	8,040	8,080	6,440	6,640	6,920	7,040	6,500	6,740	7,040	6,530
155	7,550	7,510	7,590	7,810	7,810	7,740	7,810	7,960	6,080	6,290	6,550	7,040	6,250	6,440	6,690	6,530
160	7,240	7,220	7,310	7,600	7,130	7,460	7,530	7,760	5,740	5,950	6,200	6,650	5,910	6,100	6,350	6,530
165	6,910	6,940	7,040	7,350	6,500	7,180	7,260	7,570	5,420	5,620	5,870	6,290	5,590	5,780	6,020	6,450
170	6,580	6,680	6,770	7,080	5,900	6,560	7,000	7,310	5,110	5,310	5,550	5,930	5,280	5,470	5,700	6,100
175	6,020	6,420	6,520	6,810	5,350	5,970	6,440	6,760	4,820	5,020	5,240	5,600	4,990	5,180	5,400	5,770
180	5,490	6,030	6,280	6,560	4,820	5,410	5,850	6,120	4,540	4,740	4,950	5,280	4,520	4,900	5,110	5,450
185	5,000	5,500	5,860	6,020	4,330	4,880	5,290	5,510	4,270	4,470	4,670	4,970	4,030	4,630	4,830	5,150
190	4,530	5,000	5,320	5,440	3,860	4,390	4,760	4,940	3,870	4,210	4,400	4,670	3,570	4,140	4,570	4,830
195	4,100	4,530	4,820		3,430	3,910	4,260	4,400	3,430	3,940	4,140	4,380	3,130	3,670	4,070	4,290
200	3,680	4,080	4,340		3,010	3,470	3,780	3,880	3,010	3,500	3,840	3,990	2,720	3,230	3,600	3,780
205	3,290	3,660	3,890		2,620	3,050	3,330		2,620	3,080	3,390	3,500	2,330	2,810	3,150	3,300
210	2,920	3,260	3,450		2,250	2,650	2,900		2,250	2,680	2,960		1,950	2,410	2,720	2,830
215	2,570	2,880	3,040		1,900	2,270	2,490		1,900	2,300	2,550		1,600	2,030	2,310	
220	2,240	2,510	2,640		1,570	1,900	2,090		1,570	1,930	2,160		1,270	1,670	1,920	
225	1,930	2,170	2,260		1,260	1,560	1,720		1,250	1,590	1,790			1,320	1,550	
230	1,630	1,840	1,900			1,230	1,360			1,260	1,430				1,200	
235	1,350	1,520					1,010				1,090					
240	1,090	1,220														

THIS CHART IS ONLY A GUIDE AND SHOULD NOT BE USED TO OPERATE THE CRANE.

The individual crane's load chart, operating instructions and other instructional plates must be read and understood prior to operating the crane

LOAD CHART

Insert and Hydraulic Bi-Fold Extension



44.9 ft – 205.1 ft



85 ft



26 ft



56,800 lb



100%



360°



Pounds

Radius in feet	85 ft boom extension															
	176.6 ft boom length				187.4 ft boom length				198 ft boom length				205.1 ft boom length			
	0° offset	0° – 15° offset	15° – 30° offset	30° – 50° offset	0° offset	0° – 15° offset	15° – 30° offset	30° – 50° offset	0° offset	0° – 15° offset	15° – 30° offset	30° – 50° offset	0° offset	0° – 15° offset	15° – 30° offset	30° – 50° offset
50	8,810															
55	8,810				8,060											
60	8,810				8,060				7,010				6,500			
65	8,810				8,060				7,010				6,500			
70	8,810				8,060				7,010				6,500			
75	8,810	8,800			8,060	8,050			7,010				6,500			
80	8,810	8,800			8,060	8,050			7,010	7,000			6,500	6,500		
85	8,810	8,800	8,800		8,060	8,050			7,010	7,000			6,500	6,500		
90	8,810	8,800	8,800		8,060	8,050	8,050		7,010	7,000			6,500	6,500		
95	8,810	8,800	8,800		8,060	8,050	8,050		7,010	7,000	7,000		6,500	6,500	6,740	
100	8,810	8,800	8,800	8,840	8,060	8,050	8,050	8,080	7,010	7,000	7,000		6,500	6,500	6,740	
105	8,810	8,800	8,800	8,840	8,060	8,050	8,050	8,080	7,010	7,000	7,000	7,040	6,500	6,500	6,740	
110	8,810	8,800	8,800	8,840	8,060	8,050	8,050	8,080	7,010	7,000	7,000	7,040	6,500	6,500	6,740	6,530
115	8,810	8,800	8,800	8,840	8,060	8,050	8,050	8,080	7,010	7,000	7,000	7,040	6,500	6,500	6,740	6,530
120	8,810	8,800	8,800	8,840	8,060	8,050	8,050	8,080	7,010	7,000	7,000	7,040	6,500	6,500	6,740	6,530
125	8,810	8,800	8,800	8,840	8,060	8,050	8,050	8,080	7,010	7,000	7,000	7,040	6,500	6,500	6,740	6,530
130	8,810	8,800	8,800	8,840	8,060	8,050	8,050	8,080	7,010	7,000	7,000	7,040	6,500	6,500	6,740	6,530
135	8,810	8,800	8,640	8,640	8,060	8,050	8,050	8,080	7,010	7,000	7,000	7,040	6,500	6,500	6,740	6,530
140	8,560	8,470	8,370	8,370	8,060	8,050	8,050	8,080	7,010	7,000	7,000	7,040	6,500	6,500	6,740	6,530
145	8,200	8,130	8,110	8,110	8,060	8,050	8,050	8,080	6,810	6,810	7,000	7,040	6,500	6,500	6,740	6,530
150	7,870	7,810	7,810	7,870	8,060	8,040	8,040	8,040	6,440	6,440	6,640	6,920	6,500	6,500	6,740	6,530
155	7,550	7,510	7,510	7,590	7,810	7,740	7,740	7,810	6,080	6,080	6,290	6,550	6,250	6,250	6,440	6,530
160	7,240	7,220	7,220	7,310	7,130	7,130	7,460	7,530	5,740	5,740	5,950	6,200	5,910	5,910	6,100	6,350
165	6,910	6,910	6,940	7,040	6,500	6,500	7,180	7,260	5,420	5,420	5,620	5,870	5,590	5,590	5,780	6,020
170	6,580	6,580	6,680	6,770	5,900	5,900	6,560	7,000	5,110	5,110	5,310	5,550	5,280	5,280	5,470	5,700
175	6,020	6,020	6,420	6,520	5,350	5,350	5,970	6,440	4,820	4,820	5,020	5,240	4,990	4,990	5,180	5,400
180	5,490	5,490	6,030	6,280	4,820	4,820	5,410	5,850	4,540	4,540	4,740	4,950	4,520	4,520	4,900	5,110
185	5,000	5,000	5,500	5,860	4,330	4,330	4,880	5,290	4,270	4,270	4,470	4,670	4,030	4,030	4,630	4,830
190	4,530	4,530	5,000	5,320	3,860	3,860	4,390	4,760	3,870	3,870	4,210	4,400	3,570	3,570	4,140	4,570
195	4,100	4,100	4,530		3,430	3,430	3,910	4,260	3,430	3,430	3,940	4,140	3,130	3,130	3,670	4,070
200	3,680	3,680	4,080		3,010	3,010	3,470	3,780	3,010	3,010	3,500	3,840	2,720	2,720	3,230	3,600
205	3,290	3,290	3,660		2,620	2,620	3,050		2,620	2,620	3,080	3,390	2,330	2,330	2,810	3,150
210	2,920	2,920	3,260		2,250	2,250	2,650		2,250	2,250	2,680		1,950	1,950	2,410	2,720
215	2,570	2,570	2,880		1,900	1,900	2,270		1,900	1,900	2,300		1,600	1,600	2,030	
220	2,240	2,240	2,510		1,570	1,570	1,900		1,570	1,570	1,930		1,270	1,270	1,670	
225	1,930	1,930	2,170		1,260	1,260	1,560		1,250	1,250	1,590				1,320	
230	1,630	1,630	1,840				1,230				1,260					
235	1,350	1,350														
240	1,090	1,090														

THIS CHART IS ONLY A GUIDE AND SHOULD NOT BE USED TO OPERATE THE CRANE.

The individual crane's load chart, operating instructions and other instructional plates must be read and understood prior to operating the crane

WORKING RANGE

Working Range Diagram with Heavy Duty Jib

(Boom deflection not shown)

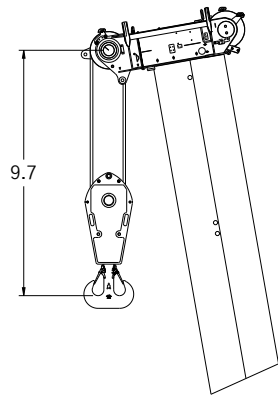
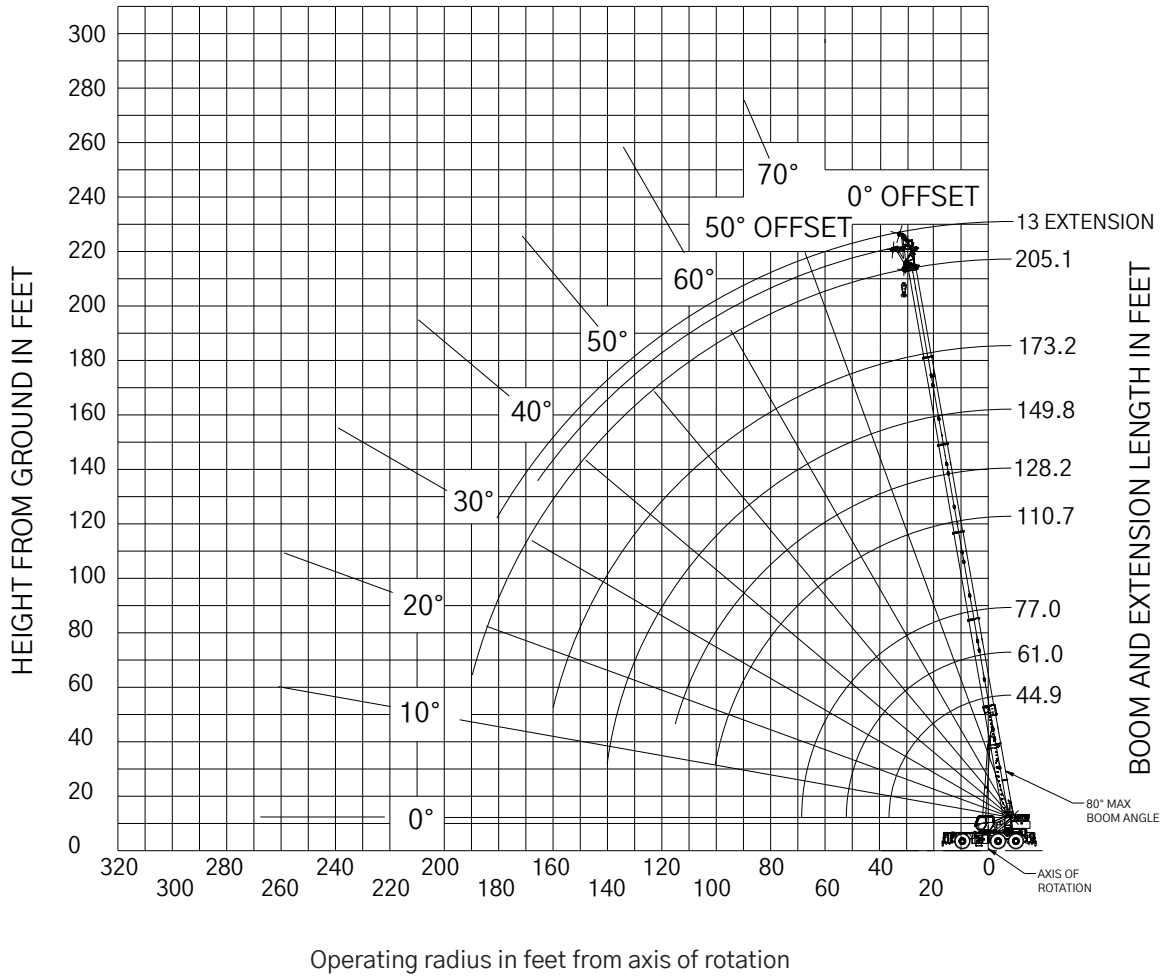

Dimensions are for the largest Grove furnished hook block, with anti-two block activated.

THIS CHART IS ONLY A GUIDE AND SHOULD NOT BE USED TO OPERATE THE CRANE.
The individual crane's load chart, operating instructions and other instructional plates must be read and understood prior to operating the crane

LOAD CHART

Heavy Duty Jib



176.6 ft – 205.1 ft



12.5 ft



56,800 lb



100%



360°



Pounds

Radius in feet	176.6 ft boom length				187.4 ft boom length				198 ft boom length				205.1 ft boom length			
	0° offset	0° – 15° offset	15° – 30° offset	30° – 50° offset	0° offset	0° – 15° offset	15° – 30° offset	30° – 50° offset	0° offset	0° – 15° offset	15° – 30° offset	30° – 50° offset	0° offset	0° – 15° offset	15° – 30° offset	30° – 50° offset
40	28,050	27,500	25,850	25,000	24,500											
45	28,050	27,500	25,850	25,000	24,500	24,100	22,650	21,600	20,600	20,400	19,150	18,200	19,100	18,650		
50	28,050	27,500	25,850	25,000	24,500	24,100	22,650	21,600	20,600	20,400	19,150	18,200	19,100	18,650	17,450	16,750
55	28,050	27,500	25,850	25,000	24,500	24,100	22,650	21,600	20,600	20,400	19,150	18,200	19,100	18,650	17,450	16,750
60	28,050	27,500	25,850	25,000	24,500	24,100	22,650	21,600	20,600	20,400	19,150	18,200	19,100	18,650	17,450	16,750
65	28,050	27,500	25,850	25,000	24,500	24,100	22,650	21,600	20,600	20,400	19,150	18,200	19,100	18,650	17,450	16,750
70	26,700	26,600	25,850	25,000	24,500	24,100	22,650	21,600	20,600	20,400	19,150	18,200	19,100	18,650	17,450	16,750
75	25,100	25,050	25,050	25,000	24,500	24,100	22,650	21,600	20,600	20,400	19,150	18,200	19,100	18,650	17,450	16,750
80	23,650	23,600	23,600	23,650	24,400	24,100	22,650	21,600	20,300	20,250	19,150	18,200	19,100	18,650	17,450	16,750
85	22,300	22,300	22,300	22,350	23,100	23,050	22,650	21,600	19,100	19,100	19,100	18,200	19,100	18,650	17,450	16,750
90	20,900	20,900	20,950	21,000	21,850	21,850	21,850	21,600	18,000	18,000	18,000	18,050	18,350	18,350	17,450	16,750
95	19,600	19,600	19,650	19,750	20,600	20,600	20,600	20,650	17,000	17,000	17,000	17,050	17,350	17,350	17,350	16,750
100	18,450	18,450	18,500	18,550	18,750	18,750	18,850	18,800	16,050	16,050	16,050	16,100	16,450	16,400	16,400	16,450
105	17,350	17,350	17,400	17,450	17,150	17,150	17,150	17,150	15,200	15,200	15,200	15,250	15,550	15,550	15,550	15,600
110	16,350	16,350	16,400	16,300	15,650	15,650	15,700	15,600	14,400	14,400	14,400	14,450	14,750	14,750	14,750	14,800
115	14,900	14,900	14,950	14,850	14,200	14,200	14,250	14,150	13,650	13,650	13,650	13,700	14,000	14,000	14,050	14,100
120	13,650	13,650	13,650	13,550	12,900	12,900	12,950	12,850	12,950	12,950	12,950	13,000	12,900	12,900	12,950	12,850
125	12,450	12,450	12,450		11,750	11,750	11,800	11,650	12,000	12,000	12,050	11,950	11,700	11,700	11,750	11,700
130	11,400	11,400	11,350		10,700	10,700	10,700		10,900	10,900	10,950	10,850	10,650	10,650	10,700	10,600
135	10,400	10,400	10,350		9,720	9,720	9,720		9,950	9,950	9,970	9,870	9,680	9,680	9,710	9,610
140	9,470	9,470	9,430		8,820	8,820	8,800		9,050	9,050	9,050		8,780	8,780	8,790	8,690
145	8,620	8,620	8,560		7,960	7,960	7,930		8,210	8,210	8,210		7,940	7,940	7,950	
150	7,830	7,820	7,760		7,170	7,170	7,130		7,430	7,430	7,410		7,170	7,170	7,160	
155	7,090	7,080	7,010		6,440	6,430	6,380		6,700	6,700	6,660		6,450	6,450	6,430	
160	6,410	6,390			5,760	5,750	5,690		6,010	6,010	5,970		5,760	5,760	5,730	
165	5,780	5,750			5,120	5,100	5,040		5,380	5,370	5,320		5,130	5,130	5,080	
170	5,190	5,150			4,530	4,500			4,780	4,770	4,710		4,530	4,530	4,480	
175	4,650	4,590			3,980	3,940			4,230	4,210	4,150		3,970	3,960	3,910	
180	1,300				3,460	3,420			3,710	3,680			3,450	3,430	3,380	
185					2,990	2,930			3,220	3,180			2,960	2,940	2,880	
190									2,760	2,720			2,500	2,470		
195									2,340	2,290			2,070	2,040		
200													1,670	1,620		
205													1,300			

THIS CHART IS ONLY A GUIDE AND SHOULD NOT BE USED TO OPERATE THE CRANE.

The individual crane's load chart, operating instructions and other instructional plates must be read and understood prior to operating the crane

LOAD CHART

Pick and Carry



44.9 ft – 205.1 ft



56,800 lb



Pick and Carry
Up to 1 mph



360°

Boom centered over rear				
Radius in feet	Main boom length in feet			
	44.9	60.9	73.5	77
25	36,400			
30	25,600	30,000	31,700	
35	22,600	22,750	25,600	25,600
40		17,600	20,200	21,300
45		13,600	16,350	17,450
50		12,350	13,300	14,400
55			10,850	11,850
60			9,200	9,900
65				8,650
Minimum boom angle (°) for indicated length (no load)				0°
Maximum boom length at 0° boom angle (no load)				77 ft

Boom angle	Lifting capacities at 0° boom angle			
	44.9	60.9	73.5	77
0°	17,100	11,400	8,740	8,120

1. Capacities are in pounds and do not exceed 75% of tipping loads as determined by test in accordance with SAE J765.
2. Capacities are applicable to machines equipped with Titan ND LCM – 26.5x25 (44 ply) tires at 94 psi (6.5 bar) cold inflation pressure.
3. Capacities are applicable only with the machine on a firm level surface.
4. On rubber lifting with boom extensions not permitted.
5. For pick and carry operation, boom must be centered over rear of machine, mechanical swing lock engaged and load restrained from swinging.
6. Axle lockouts must be functioning when lifting on rubber.
7. All lifting depends on proper tire inflation, capacity and condition. Capacities must be reduced for lower tire inflation pressures. See the tire inflation table for tire specifications. Damaged tires are hazardous to safe operation of crane.
8. Creep – not over 200 ft (61 m) of movement in any 30 minute period and not exceeding 1 mph (1.6 km/h).

THIS CHART IS ONLY A GUIDE AND SHOULD NOT BE USED TO OPERATE THE CRANE.

The individual crane's load chart, operating instructions and other instructional plates must be read and understood prior to operating the crane

RIGGING CHARTS

Rigging chart for installation and removal of outrigger boxes without counterweight, stationary on rubber, 360°			
Radius in feet	Main boom length in feet		
	44.9	60.9	73.5
10	17,000	18,000	
12	17,000	18,000	18,000
15	17,000	18,000	18,000
20	9,030	13,500	13,500
Minimum boom angle (°) for indicated length (no load)	54°	65°	69°
*This capacity is based on maximum boom angle			

Rigging chart for installation and removal of counterweight, on outriggers fully extended, 360°			
Radius in feet	Main boom length in feet		
	44.9	60.9	73.5
10	100,000	90,000	85,000
12	100,000	90,000	83,750
15	100,000	90,000	74,950
20	100,000	86,900	63,700
25	100,000	76,550	55,250
30	75,000	68,450	48,800
35	52,950	58,700	43,600

1. Capacities do not exceed 75% of tipping loads as determined by test in accordance with SAE J765.
2. Capacities are applicable to machines equipped with Titan 26.5x25 (44 ply) tires at 94 psi (6.5 bar) cold inflation pressure.
3. Capacities are applicable only with the machine on firm level surface.
4. On rubber lifting with boom extensions not permitted.
5. With no load, do not exceed a 25 ft (8 m) load radius over sides of the machine since a loss of stability could occur causing a tipping condition. To lower the boom into a horizontal position, swing the boom directly over the front of the machine and either fully retract the boom or switch the RCL system into a rigging table.
6. Once one outrigger box is installed, do not swing the load over that end of the machine while installing the other outrigger box.
7. Each outrigger box assembly weighs 8,900 lb (4037 kg), including the outrigger beams and pads.
8. Axle lockouts must be functioning when lifting on rubber. Lockout cylinders must be inflated to 100% when lifting on rubber 360 degrees.
9. All lifting depends on proper tire inflation, capacity, and condition. Capacities must be reduced for lower tire inflation pressures. See the tire inflation table for tire specifications. Damaged tires are hazardous to safe operation of the crane.

THIS CHART IS ONLY A GUIDE AND SHOULD NOT BE USED TO OPERATE THE CRANE.

The individual crane's load chart, operating instructions and other instructional plates must be read and understood prior to operating the crane

LOAD HANDLING

Weight reductions for load handling devices

Auxiliary boom nose	195 kg (430 lb)
Hook blocks and overhaul weights:	
120 t (134 USt), 8-sheave	1180 kg (2601 lb)*
100 t (112 USt), 7-sheave	1140 kg (2513 lb)*
75 t (83 USt), 5-sheave	1070 kg (2359 lb)*
45 t (50 USt), 3-sheave	770 kg (1698 lb)*
26 t (29 USt), 1-sheave	535 kg (1179 lb)*
11 t (12 USt) overhaul weight	380 kg (838 lb)*
11 t (12 USt) overhaul ball	378 kg (833 lb)*

*Refer to rating plate for actual weight.

Tire inflation — bar (psi)

Size (front and rear)	TRA Code	Lifting service, general travel and extended travel
		Static, creep and 4.0 km/h (2.5 mph)
26.5 x 25 - 44 PR	E-3 / L-3	6.48 bar (94 psi)

Line pulls and reeving information

Hoists	Cable specs.	Permissible line pulls	Nominal cable length
Main	19 mm (3/4 in) 35x7 Class rotation resistant (non-rotating) Min. breaking strength 38 918 kg (85,800 lb)	7784 kg (17,160 lb)*	294 m (964.5 ft)
Auxiliary	19 mm (3/4 in) 35x7 Class rotation resistant (non-rotating) Min. breaking strength 38 918 kg (85,800 lb)	7784 kg (17,160 lb)*	233 m (764.4 ft)

The approximate weight of 19 mm (3/4 in) wire rope is 2.2 kg/m (1.5 lb/ft). *With certain boom and hoist tackle combinations, the allowable line pull may be limited by hoist performance. Refer to Hoist performance table for lift planning to ensure adequate hoist performance on drum rope layer required.

11.2 m – 17.8 m (36.7 ft – 58.4 ft) boom extension (manual or hydraulic) and 3.8 m (12.5 ft) heavy duty jib

	Without overhaul weight or hookblock	With 380 kg (838 lb) overhaul weight	With 770 kg (1698 lb) hookblock
11.2 m (36.7 ft) extension (erected)*	2041 kg (4500 lb)	3810 kg (8400 lb)	N/A
17.8 m (58.4 ft) extension (erected)*	3266 kg (7200 lb)	5987 kg (13200 lb)	N/A
3.8 m (12.5 ft) heavy duty jib (erected)*	1134 kg (2500 lb)	1814 kg (4000 lb)	2313 kg (5100 lb)

*Reduction of main boom capacities

NOTE:

- All load handling devices and boom attachments are considered part of the load and suitable allowances MUST BE MADE for their combined weights. Weights are for Grove furnished equipment.
- When operating at temperatures below -40°C (-40°F), capacities shall be derated 3.6% of rated load for each degree Fahrenheit below -40°C (-40°F) without shock load.
- When lifting over swingaway and/or jib combinations, deduct total weight of all load handling devices reeved over main boom nose directly from swingaway or jib capacity.

Hoist performance

Wire rope layer	Hoist line pulls	Layer capacity	Total drum capacity
1	10 000 kg (22,100 lb)	33,8 m (111 ft)	33,8 m (111 ft)
2	9250 kg (20,400 lb)	36,6 m (120 ft)	70,4 m (231 ft)
3	8570 kg (18,900 lb)	39,6 m (130 ft)	110 m (361 ft)
4	7980 kg (17,600 lb)	42,4 m (139 ft)	152 m (500 ft)
5	7480 kg (16,500 lb)	45,4 m (149 ft)	198 m (649 ft)
6	7030 kg (15,500 lb)	48,2 m (158 ft)	246 m (807 ft)
7	6620 kg (14,600 lb)	51,2 m (168 ft)	297 m (976 ft)

*Refer to Line pulls and Reeving information table for max. lifting capacity of wire rope.

Working area diagram

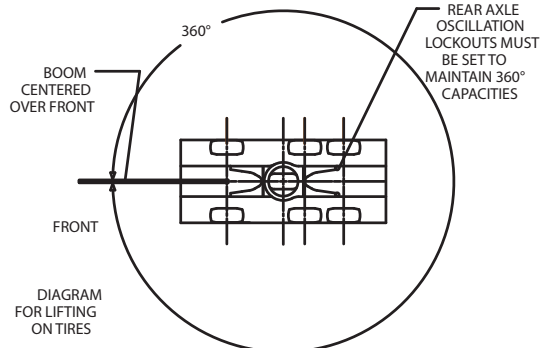
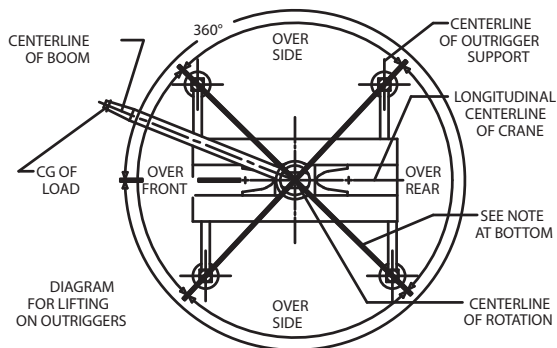

Bold lines determine the limiting position of any load for operation within working areas indicated.

THIS CHART IS ONLY A GUIDE AND SHOULD NOT BE USED TO OPERATE THE CRANE.

The individual crane's load chart, operating instructions and other instructional plates must be read and understood prior to operating the crane

SPECIFICATIONS

Superstructure



Boom

BOOM: 13,7 m to 62,5 m (44.9 ft to 205 ft) six-section MEGAFORM™ boom with TWIN-LOCK™ boom pinning system. Maximum tip height: 214 ft (65.2 m)



Boom Nose

Seven nylon sheaves mounted on heavy-duty tapered roller bearings with removable pin type guards. Quick reeve boom nose. Removable single sheave auxiliary boom nose with removable pin-type rope guard.



Boom Elevation

Single hydraulic cylinder with integral holding valve provides boom elevation from -2° to $+80^{\circ}$.



Manual Bi-Fold Swingaway Extension*

11,2 m – 17,8 m (36.7 ft – 58.4 ft) bi-fold lattice swingaway extension. Offsets at 0° , 15° , 30° and 50° . Stows alongside base boom section. Maximum tip height: 83,2 m (273 ft)



Hydraulic Bi-Fold Swingaway Extension*

11,2 m – 17,8 m (36.7 ft – 58.4 ft) bi-fold lattice swingaway extension. Hydraulically offsets from 0° to 50° . Controlled from crane cab. Stows alongside base boom section. Maximum tip height: 83,2 m (273 ft)



Lattice Insert*

One 8 m (26.2 ft) lattice insert. Provides a total extension length of 25.8 m (84.6 ft) when paired with the bi-fold swingaway extension. Maximum tip height: 91,1 m (299 ft)



Heavy Duty Jib*

3,8 m (12.5 ft) two sheave, heavy duty jib, hydraulically offset from 0° to 50° . Controlled from crane cab. Maximum tip height: 69 m (226.5 ft).



Crane Control System

Rated Capacity Limiter (RCL) with graphical display. Load moment and anti-two block system with audio-visual warning and control lever lockout. This system provides electronic display of boom angle, boom length, load radius, boom tip height, maximum permissible load, actual load and warning of impending two-block condition. Also includes an Operating display which shows the crane operating indicators, levels, warnings and faults. Other features include a Working Range Limiter (WRL) which allows the operator to preselect and define working areas. If the crane approaches the operator preset limits, audio-visual warnings aid the operator in avoiding obstructions. ECO mode system to control engine rpm to lower noise and improve fuel consumption. Operator-programmable function speeds and ramps. On Crane Service Interface (oCSI) provides on-board diagnostics.



Cab

Operator-controlled 20° hydraulic cab tilt, full vision, all steel fabricated with acoustical lining and tinted safety glass throughout. Deluxe seat with headrest, incorporates armrest-mounted electronic programmable single-axis or dual-axis controllers and a jog dial for easy data input. Tilt/telescoping steering wheel with controls incorporated into the steering column. Three camera system provides visibility of the rear, right side and hoists via in cab display. Other standard features include heater (hot water), circulating air fan, high-output air conditioning system, sliding skylight with sunscreen, windshield and skylight washer/wiper, windshield sun visor, fire extinguisher, seat belt, USB charging port, pivoting cup holder, and dual cab-mounted work lights.



Swing

Variable speed, 360° continuous rotation. Planetary swing drive with foot actuated multi-disc brake. Spring-applied, hydraulically released swing brake. Two-position mechanical swing lock pin, operated from cab. Maximum speed: 1.1 rpm



Counterweight

25 764 kg (56,800 lb) hydraulically installed and removed. Controlled via CCS operating display in cab or via wireless rigging remote.



Hoist (main and optional auxiliary hoist)

Main and auxiliary hoists with grooved drums, axial piston motors, planetary gears and multiple disc brakes. Electronic hoist drum rotation indicator alerts operator of hoist movement. Third wrap indicator with hoist function cut-out and hoist camera is standard.

HOIST LINE PULL

First layer: 10 000 kg (22,100 lb)

Max. line speed: 132 m/min (432 ft/min)

Max. permissible line pull: 7784 kg (17,160 lb)

Rope construction: 35 x 7 rotation-resistant

Rope diameter: 19 mm (3/4 in)

Rope length: Main hoist: 294 m (964.5 ft)

Auxiliary hoist: 233 m (764.4 ft)

* Denotes optional equipment

SPECIFICATIONS

Carrier



Chassis

Parallel box section fabricated from high-strength, low-alloy steel. Removable outrigger boxes. Front and rear lift, towing and tie-down lugs.



Outrigger System

Four hydraulic telescoping, single-stage, double box beam outriggers with inverted jack cylinders and integral holding valves. Three position settings: 0%, 50% and 100% (fully extended). Outrigger Monitoring System (OMS) with in-cylinder sensors. Outrigger beam position shown on RCL display. Outrigger boxes are removable for ease of transportation, with pinning controls on the carrier. Steel outrigger floats 610 mm (24 in) diameter. Maximum outrigger pad load: 75 297 kg (166,000 lb)



Outrigger Controls

Main controls and digital level shown on operating display in cab. Extension and retraction are through the CCS system as well as the wireless rigging remote. Includes automatic leveling feature.



Hydraulic System

Two piston pumps and two gear pumps with a combined capacity of 573 l/min (151.5 gpm)

Maximum operating pressure: 300 bar (4350 psi)

Return line in-tank filter with full flow by-pass protection and service indicator. Replaceable cartridge with 4-micron filtration rating per ISO cleanliness level of 17/15/12. Superstructure-mounted oil cooler with thermostatically controlled electric motor driven fan/air to oil. System pressure test ports. 738 l (195 gal) hydraulic reservoir.



Engine (Tier 4 Final / Stage V)

Cummins B6.7L diesel engine with after-treatment system. Six-cylinder, turbo-charged and after-cooled engine. 224 kw (300 HP) at 2,500 rpm. Maximum torque: 1288 Nm (950 lb-ft) at 1500 rpm.

Meets emissions per U.S. EPA Tier 4 Final and E.U. Stage V.

Fuel requirement: Maximum of 15 ppm sulfur content (ultra low sulfur diesel). Diesel exhaust fluid required.

Please review your country's appropriate engine emissions standards before selecting an engine.



Engine (Non-Certified)

Cummins B6.7L diesel engine without aftertreatment system. Six-cylinder, turbo-charged and after-cooled engine. 224 kw (300 HP) at 2,500 rpm. Maximum torque: 1288 Nm (950 lb-ft) at 1500 rpm.

Fuel requirement: Maximum of 5000 ppm sulfur diesel fuel.

Please review your country's appropriate engine emissions standards before selecting an engine.



Fuel Tank Capacity

312 l (82 gal)



Transmission

Rangeshift with torque convertor. Six forward and six reverse speeds. (Three speeds high and three speeds low). Rear axle disconnect for two-wheel drive.



Axles

Axle 1: Drive/steer with differential and planetary reduction hubs rigid mounted to frame.

Axle 2: Steer only. Automatic full hydraulic lockouts on rear axle permits 152 mm (6 in) of oscillation for jobsite travel.

Axle 3: Drive/steer with differential and planetary reduction hubs. Automatic full hydraulic lockouts on rear axle permits 152 mm (6 in) of oscillation for jobsite travel.



Brakes

Full hydraulic split (dual) circuit dry disc operating on all wheels with dual calipers. High-pressure parking brake is spring applied/hydraulically released, mounted on the front axle.



Steering

Fully independent hydraulic power steering. Front axle controlled via steering wheel. Rear axles are mechanically linked and are controlled via separate momentary switch in cab. Rear steer alignment indicator included.

Four steering modes: two-wheel front, four-wheel rear, six-wheel coordinated and six-wheel crab. Outside six-wheel coordinated steer radius: 10,2 m (33.5 ft). Inside six-wheel coordinated steer radius: 7,4 m (24.2 ft)

SPECIFICATIONS

Carrier (cont.)



Suspension

Front axle: Rigid mounted to frame.

Rear axles: Hydro-gas suspension that provides +/- 76,2 mm (3 in) of travel from ride height for reduced transportation height.



Tires

26.5 x 25 - 44 bias ply rating



Electrical System

Two 12 V maintenance-free batteries provide 24 V electrical system. Lockable battery disconnect located on carrier.



Lighting

Full LED lighting package, including turn indicators; head, tail, brake and hazard warning lights; and work lights mounted on cab front.



Maximum Drive Speed

12 km/h (7.5 mph) with full counterweight (boom over front w/ boom angle between 0° and 20°)

4 km/h (2.5 mph) with no counterweight (boom over front w/ boom angle between 0° and 20°)



Gradeability (theoretical)

93% to drivetrain stall based on 86 996 kg (191,793 lb) GVW with 26.5 x 25 tires, 25 764 kg (56,800 lb) counterweight, main and auxiliary hoist, manual bi-fold extension, 100 t (112 USt) hook block and 11 t (12 USt) overhaul weight.

Miscellaneous Standard Equipment

Full-length aluminum decking, dual rear-view mirrors, hook block tie-down, electronic back-up alarm, carrier storage boxes, cab heat and air conditioning system, Operating hour display, A/V warning system, combination lift/tie-down/towing lugs, hoist access platform, sling assemblies for self-rigging of removable components, cab-controlled differential locks, and wireless rigging remote.

* Optional equipment

- Auxiliary Lighting and Convenience Package: Includes superstructure-mounted amber flashing beacon, dual base boom mounted floodlights controlled from cab, in-cab RCL light bar and rubber mat for storage trough.
- 11,2 m to 17,8 m (36.7 ft to 58.4 ft) bi-fold swingaway, hydraulically offset from 0° to 50° in lieu of the standard manually offsettable swingaway
- 1 x 8 m (26.2 ft) lattice boom insert
- 3,8 m (12.5 ft) two sheave, heavy duty jib, hydraulically offset from 0° to 50°
- Boom nose-mounted, boom position indicator light
- Wind speed indicator
- Bluetooth/AM/FM radio
- Vertical RCL light tower (external)
- Heated seat
- Emergency stop buttons on each side of carrier
- Rear pintle hitch
- 360° NYC-style mechanical swing lock
- -29°C/-20°F cold weather package
- -40°C/-40°F arctic weather package
- CraneSTAR telematic system

* Denotes optional equipment



NOTES

The Manitowoc Company, Inc.

Regional headquarters

Americas

Milwaukee, Wisconsin, USA
Tel: +1 414 760 4600

Shady Grove, Pennsylvania, USA
Tel: +1 717 597 8121

Europe and Africa

Dardilly, France – TOWERS
Tel: +33 (0) 4 72 18 20 20

Wilhelmshaven, Germany – MOBILE
Tel: +49 (0) 4421 294 0

APAC

Shanghai, China
Tel: +86 21 6457 0066

Singapore
Tel: +65 6264 1188

Middle East and India

Dubai, UAE
Tel: +971 4 8862677

