

# SPECIFICATIONS

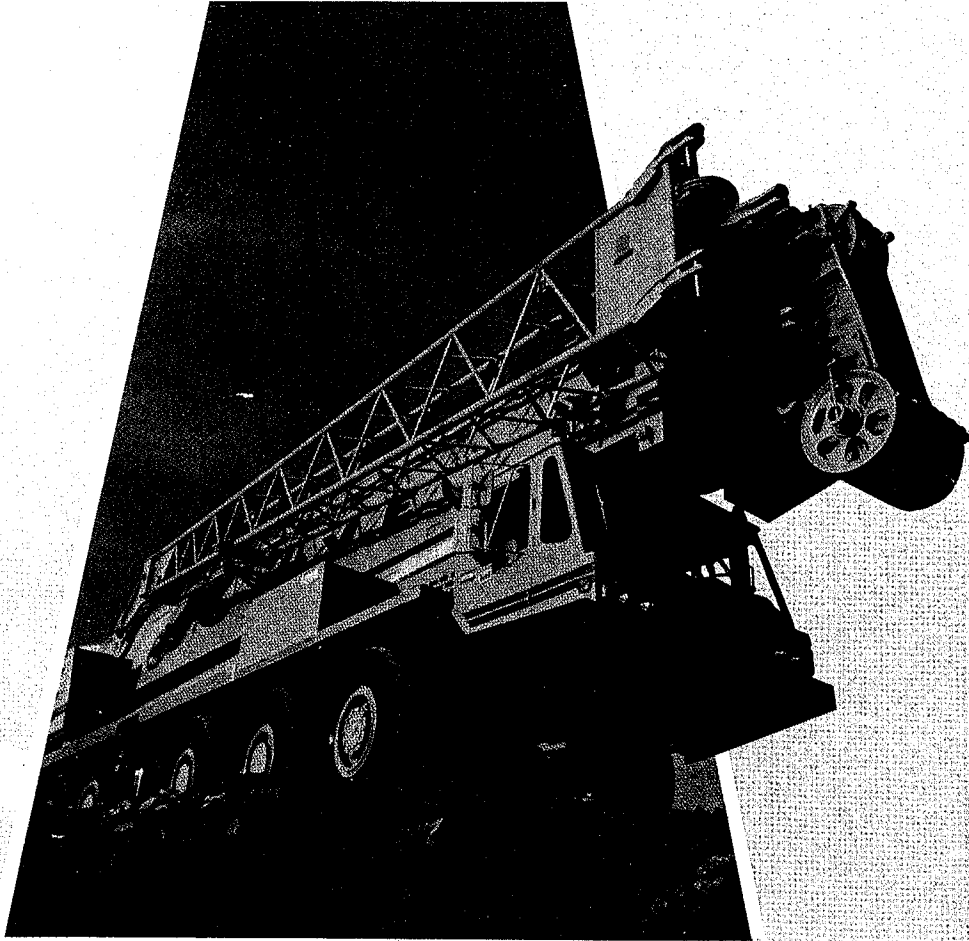

WORLD  
LEADER  
IN

**HYDRAULIC  
CRANES**

# SPECIFICATIONS

## SUPERSTRUCTURE

**BOOM** - 47 ft. - 175 ft. (14.3m - 53.3m) total length; 5-section Trap-Lock<sup>††</sup> Trapezoidal Main Boom consisting of base section and four full-power sections to 175 ft. (53.3m). Powered sections are individually-sequenced by a single, double-acting 10 in. bore X 36 ft. 1 in. (254mm X 10998mm) cylinder with integral holding valve. The operator pre-selects extension sequence. Cab-Controlled power-actuated pins engage the telescope cylinder to each section for power extension and retraction. Boom sections are individually controlled, automatically lock in sequence, and are supported on graphite-impregnated nylatron wear pads.

**BOOM EXTENSION** - 34 ft. (10.4m) lattice "Swingaway" boom extension extends the reach of the Main Boom to 208 ft. (63.4m) and stows alongside the boom base section. Round tube four-cord construction is utilized with an offset nose and sheave arrangement consisting of one upper idler sheave and one lower point sheave, 24-3/4 in. (629mm) tread diameter mounted on heavy-duty tapered roller-bearings.

**BOOM NOSE** - Ten load-bearing sheaves and three idler sheaves, 24-3/4 in. (629mm) tread diameter mounted on heavy-duty tapered roller-bearings. Removable cable guides allow easy reeving. Rope dead-ends on either side of boom nose. Two outer sheaves on each side are removable.

**AUXILIARY BOOM NOSE** - Removable, single-sheave, auxiliary boom nose with 24-3/4 in. (629mm) tread diameter sheave is mounted on heavy-duty tapered roller-bearings.

**\*FIXED-OFFSET JIB** - 18 ft. (5.5m) lattice base section combines with either one or two additional 18 ft. (5.5m) sections to produce a 36 ft. (11m) or 54 ft. (16.5m) jib. Mast, pendant lines, attaching hardware and backstops are included in the makeup of all jib lengths. Jib sheave (24-3/4 in. [629mm]) is mounted on tapered roller-bearings. The jib attaches to the standard 34 ft. (10.4m) "Swingaway" extension, is cable-suspended and offsets at either 10° or 30°.

**\*POWER LUFFING JIB** - 19 ft. (5.8m) lattice base section combines with one (1) 20 ft. (6.1m) pinned insert and a 19 ft. (5.8m) jib point section to make basic 58 ft. (17.7m) cable suspended power luffing jib. Additional 20 ft. (6.1m) pinned inserts available to make 78 ft. (23.8m), 98 ft. (29.9m), 118 ft. (36.0m), 138 ft. (42.1m) to a maximum length of 158 ft. (48.2m). Luffing power is supplied from the standard auxiliary hoist or the optional second auxiliary hoist if the machine is equipped with three hoists. With the luffing jib in operation, the load line hoist will be either the main hoist or in the case of the optional three hoist configuration, the number one auxiliary hoist. Offset capability will be between 72° through 0°. Mast, pendant line, attaching hardware and backstops included in the makeup of all jib lengths. Two point sheaves with tapered roller bearings are included in the 19 ft. (5.8m) jib point section.

**BOOM ELEVATION** - Dual, double-acting 16-in. (406mm) bore hydraulic cylinders with integral holding valves. Elevation from -3° to 84°. Combination controls provided for hand or foot operation.

**LOAD MOMENT AND ANTI-TWO BLOCK SYSTEM (Krueger "LMI")** - A load moment indicating system in combination with anti-two block, audio-visual and Grove control lever lockout of: hoist up, telescope out and boom down crane functions. System uses solid state circuitry and consists of following basic components: boom nose mounted switch and weight assembly, base boom mounted electric cable reel and in-cab mounted console. Dash mounted console displays relative load moment and also provides selective electronic display of boom length in feet and meters and angle in degrees. Angle indicator has "presets" with audio-visual warning system to alert operator if preset boom angles are reached.

**CAB** - All-steel, full-vision-type mounted on left side, fully-enclosed with acoustical treatment and tinted safety-glass throughout. Sliding left side door, sliding right side glass and hinged tinted skylight for ventilation. Electric windshield and skylight wiper, electric windshield washer, circulating air fan, swing horn, domelight, dashlight, cigarette lighter, ashtray, circular outrigger leveling bubble, door and window locks, 15,000 BTU/HR (4.4 kw) hot water heater and forced hot air defroster and 2-3/4 lb. (1.3kg) fire-extinguisher. Fully-adjustable operator's seat with head and arm rests, complete engine instrumentation and crane operating controls, combination hand/foot controls for boom elevation and engine throttle, electronic hoist drum rotation indicators for main and auxiliary hoists.

**CAB CONTROLS** - Separate dash-mounted hand levers for swing, boom telescope, boom elevation and main and auxiliary hoists. Foot controls provided for swing brake, boom elevation and engine throttle. Additional controls include electric/hydraulic swing parking brake, 360° position positive turntable lock, engine throttle lock, engine stop, hoist speed selection, boom extension sequence and latching, engine-start-and-stop switch, heater, defroster, interior/exterior lights, windshield and skylight wipers, windshield washer, etc.

NOTE: Outrigger controls and leveling bubble located on both sides of carrier frame.

**CAB INSTRUMENTATION** - Engine monitoring controls include oil pressure gauge, water temperature gauge, voltmeter, tachometer and high water temperature/low oil pressure warning light. Other indicators include fuel level gauge, hydraulic filter bypass light, main and auxiliary hoist out-of-gear light, boom extension sequence and latching lights, Krueger LMI and anti-two-block system console with display of relative load moment, boom length, operating radius and boom jib/angle.

**SWING** — Roller-bearing swing circle, 360° continuous rotation. Rockwell planetary "glide swing" with foot-actuated disc swing brake, electric/hydraulic swing parking brake and 360° position, cab-controlled, positive turntable-lock. Maximum swing speed: 1 RPM.

**COUNTERWEIGHT** - 60,000 lbs. (27,216 kg) turntable-mounted. Hydraulically power-installed and removed.

**HYDRAULIC SYSTEM:**

**RESERVOIR** — 325 gallons (1230 liters) capacity, all-steel welded construction with integral baffles, clean-out access, sight level gauge and tank-mounted filter with hydraulic oil temperature gauge and magnetic plugs.

**OIL FILTERS** - Tank-mounted, return-line type, full flow with bypass protection and filter bypass indicator in cab, replaceable cartridge. 25-micron rating. One each high-pressure line, 6-micron filter in each pump circuit.

**PUMPS** - 5 sections (one tandem, one three-section), gear-type, driven by superstructure engine. Manual pump disconnect located on lower left side of superstructure. Combined capacity 241 GPM (912 Lpm) @ 2400 RPM.

**CONTROL VALVES** - Precision four-way, double acting with integral load check, main and circuit relief valves. Five individual valve banks permit simultaneous independent control of four crane functions. Maximum system operating pressure of 3000 PSI (211 kg/cm<sup>2</sup>).

**OIL COOLER** - Superstructure-mounted; oil to air, with thermostatically-controlled hydraulic motor-driven fan.

**POWER DISTRIBUTION** - First valve bank - 70 GPM (265 Lpm), main hoist at 3000 PSI (211 kg/cm<sup>2</sup>), \*2nd auxiliary hoist @ 2500 PSI (176 kg/cm<sup>2</sup>). Second valve bank - 70 GPM (265 Lpm), main hoist boost, telescope and boom elevation @ 3000 PSI (211 kg/cm<sup>2</sup>), first auxiliary hoist boost @ 2500 PSI (176 kg/cm<sup>2</sup>). Third valve bank - 51 GPM (193 Lpm), boom elevation boost and telescope boost @ 2500 PSI (176 kg/cm<sup>2</sup>). Fourth valve bank - 25 GPM (95 Lpm), swing @ 2500 PSI (176 kg/cm<sup>2</sup>). Fifth valve bank - 25 GPM (95 Lpm), counterweight removal and luffing idler sheave installation erection @ 2500 PSI (176 kg/cm<sup>2</sup>).

**MISCELLANEOUS STANDARD EQUIPMENT** - Hydraulic reservoir shutoff valve, base boom mounted floodlight, air dryer.

\*Denotes Optional Equipment  
†Patented Grove Feature  
††Patent Pending

# SPECIFICATIONS

## HOIST SPECIFICATIONS

DESCRIPTION: Three speeds and three line pulls with planetary gearing and vane-type hydraulic motor for power up and down operation. Integral automatic multi-disc brake.			
HOIST DATA	MAIN HOIST GEARMATIC MODEL 54		
DRUM DIMENSIONS	24 in. (610mm) dia. 38 in. (965mm) length 40 in. (1016mm) flange dia.		
PERFORMANCE (No Load) MAX. SINGLE LINE SPEED	HIGH RANGE	INTERMEDIATE	LOW RANGE
BARE DRUM	477 FPM (145 m/min)	272 FPM (83 m/min)	153 FPM (47 m/min)
MEAN DRUM	562 FPM (171 m/min)	320 FPM (98 m/min)	180 FPM (55 m/min)
FULL DRUM (4th Layer)	688 FPM (210 m/min)	393 FPM (120 m/min)	221 FPM (67 m/min)
MAX. SINGLE LINE PULL			
BARE DRUM	10,944 lbs. (4964 kg)	19,152 lbs. (8687 kg)	33,927 lbs. (15389 kg)
MEAN DRUM	9,299 lbs. (4218 kg)	16,273 lbs. (7381 kg)	28,827 lbs. (13076 kg)
FULL DRUM	7,588 lbs. (3442 kg)	13,279 lbs. (6023 kg)	23,523 lbs. (10670 kg)
DRUM ROPE CAPACITY +MAX. STORAGE ++MAX. USABLE	1838 ft. of 1-1/8 in. dia. rope (560m of 28.6mm) 1239 ft. of 1-1/8 in. dia. rope (378m of 28.6mm)		
PERMISSIBLE SINGLE LINE PULL WITH 5:1 SAFETY FACTOR 6:1 SAFETY FACTOR	1-1/8 in. (28.6mm) 18x19 class EIPS 25,600 lbs. (11612 kg) 1-1/10 in. (28mm) Dyform 34LR 24,203 lbs. (10978 kg)		

**NOTES:**

\*7th layer of rope not recommended for hoisting operations.  
 \*\*With wire rope minimum 1/2 in. (13mm) below top of drum flange.

## Optional 3rd Hoist

## INCREASES VERSATILITY & BOOSTS PROFIT POTENTIAL

In addition to the common two-hoist configuration found on many hydraulic cranes, the TM2500 accommodates an optional third hoist. The added hoist line enhances jobsite versatility by permitting full load-handling use of the main and first auxiliary hoists, plus having the extra hoist line for control of the power-luffing jib.

In the above specification chart, note that the Model 44 two-speed planetary-drive hydraulic hoist is used for both the standard first auxiliary and optional second auxiliary hoists. Performance figures are the same for both except that the unit to be used to power the luffing jib is equipped with a remote-controlled positive pawl-and-

ratchet locking system. With a maximum usable capacity of over 1,000 feet (305m) of 1-inch (25mm) wire rope, the third hoist can easily lower the luffing jib to a vertically-suspended attitude for overnight jobsite stowage and security.

Note also that the Model 54 Main Hoist carries 1-1/8 in. (28.6mm) cable and has a maximum line pull capability of 33,927 lbs. (15389 kg), bare drum rating in low-speed range. Maximum line speed is 688 feet or 210 meters per minute.

The two standard hoists are mounted on the main superstructure. The optional third hoist is mounted on the removable counterweight.

# HOIST SPECIFICATIONS (Auxiliary)

DESCRIPTION: Two speed and pull; planetary drive, power up and down with integral automatic brake.		
HOIST DATA	AUXILIARY & 2nd AUXILIARY HOIST GEARMATIC MODEL 44	
DRUM DIMENSIONS	20 in. (508mm) dia. 32 in. (813mm) length 30 in. (762mm) flange dia.	
PERFORMANCE (No Load) MAX. SINGLE LINE SPEED	<b>HIGH RANGE</b>	<b>LOW RANGE</b>
BARE DRUM	260 FPM (79 m/min)	130 FPM (40 m/min)
MEAN DRUM	315 FPM (96 m/min)	155 FPM (47 m/min)
FULL DRUM (4th Layer)	360 FPM (110 m/min)	180 FPM (55 m/min)
MAX. SINGLE LINE PULL		
BARE DRUM	14,000 lbs. (6350 kg)	28,000 lbs. (12701 kg)
MEAN DRUM	12,000 lbs. (5443 kg)	24,000 lbs. (10886 kg)
FULL DRUM	10,000 lbs. (4536 kg)	20,000 lbs. (9072 kg)
DRUM ROPE CAPACITY	1264 ft. of 1 in. dia. rope (385m. of 25mm)	
+MAX. STORAGE	1018 ft. of 1 in. dia. rope (310m. of 25mm)	
++MAX. USABLE		
PERMISSIBLE SINGLE LINE PULL WITH 5:1 SAFETY FACTOR	1 in. (25mm) 18x19 class EIPS 20,400 lbs. (9253 kg)	
6:1 SAFETY FACTOR	1 in. (25mm) 18x19 class EIPS 17,000 lbs. (7711 kg)	

**NOTES:**

+7th layer of rope not recommended for hoisting operations.  
 ++With wire rope minimum 1/2 in. (13mm) below top of drum flange.

# DIMENSIONS

# MORE CRANE NOT MORE SIZE

Bumper Clearance  
45' 2-7/16"  
(13 777)

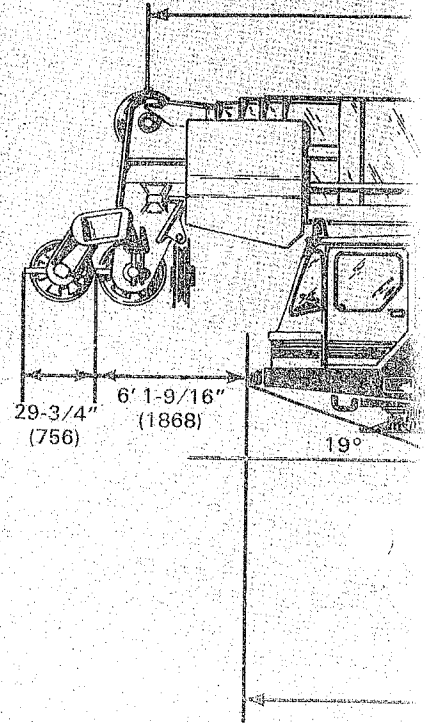
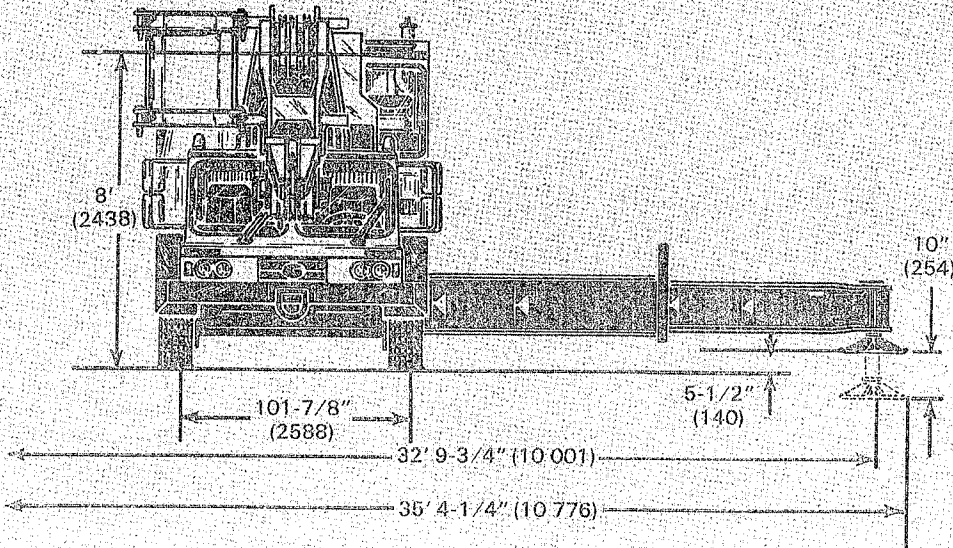
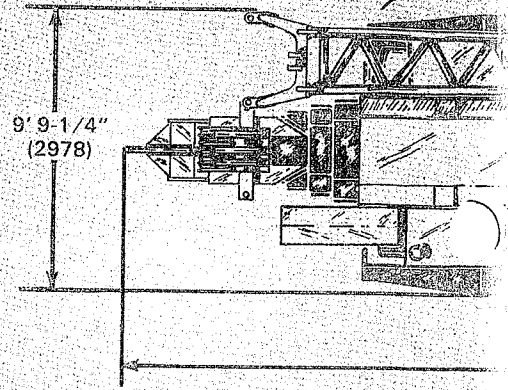

NOTE: Dimensions shown in parentheses are in millimeters (mm).

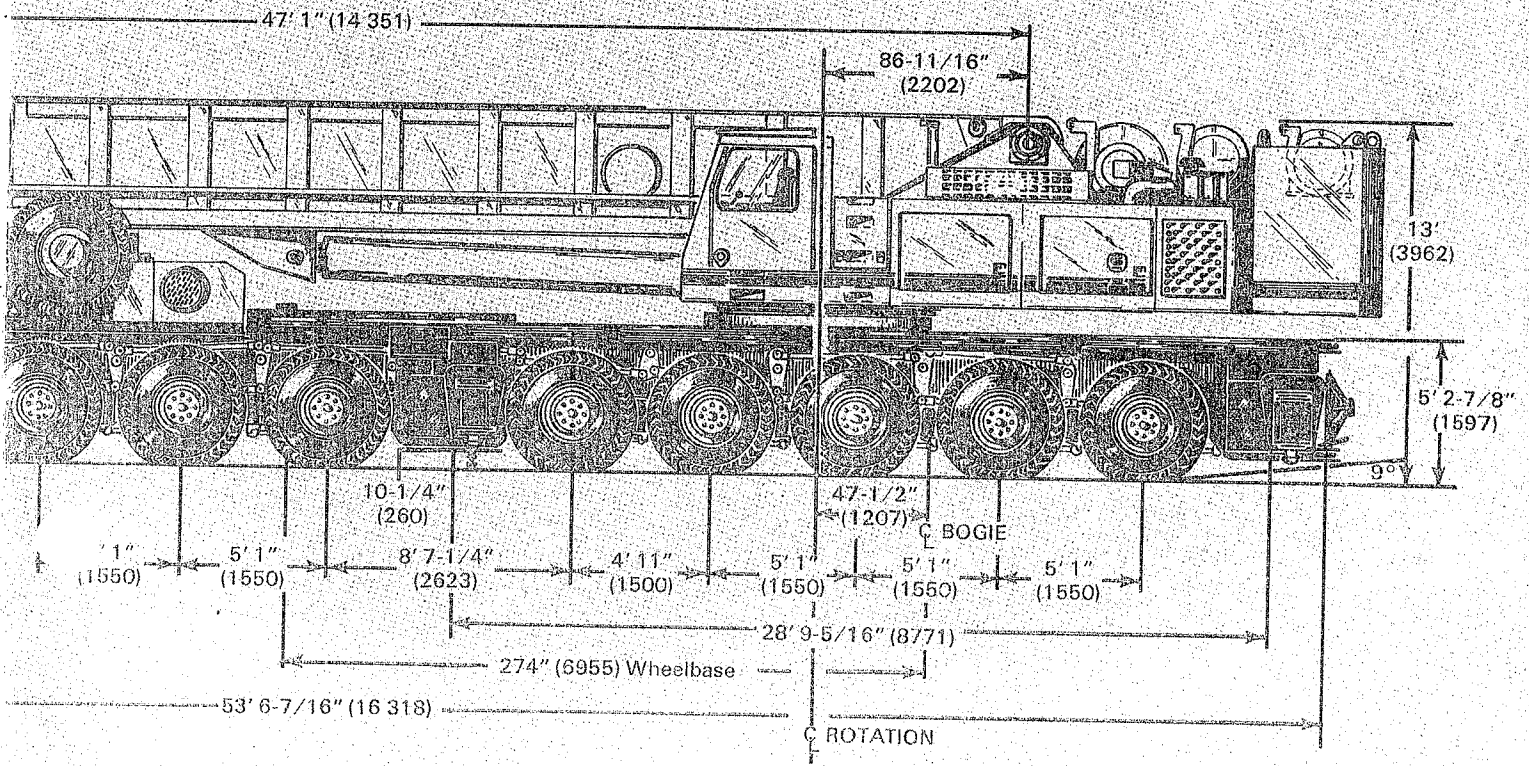
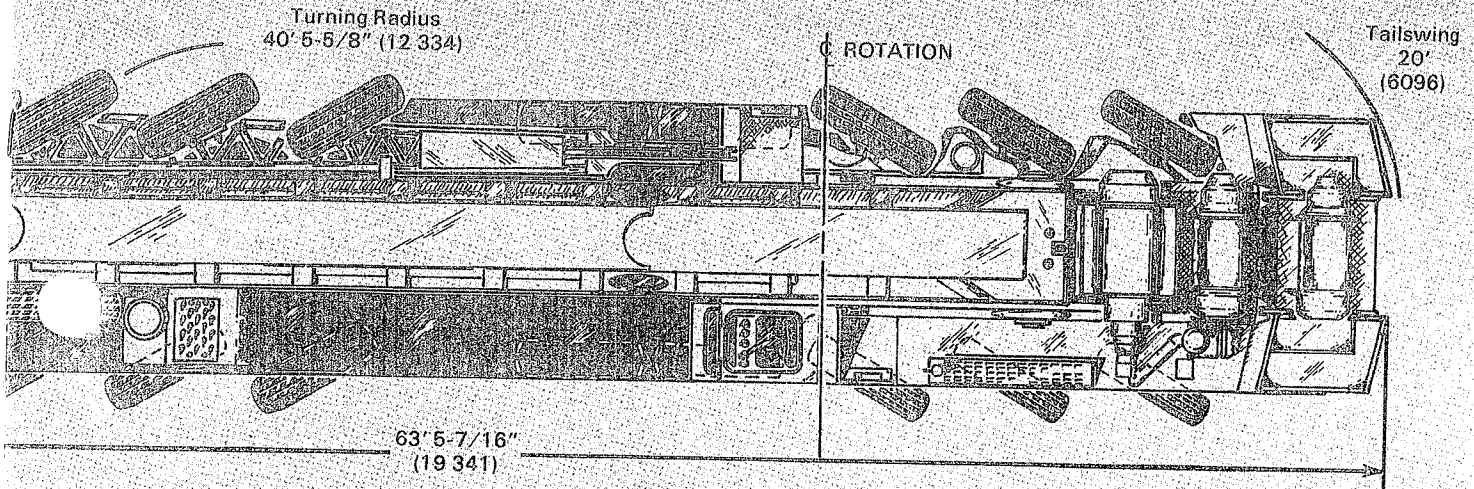

# SPECIFICATIONS

## CARRIER

**OUTRIGGERS** - Hydraulic double box, two-stage telescoping beam outriggers having integral welded boxes, removable beams, vertical 9 in. (229mm) bore X 10 in. (254mm) stroke, double-acting jack cylinders with integral holding valves and 30-1/2 in. (775mm) diameter high strength steel fabricated floats. Outrigger beams extend to 32 ft. 9-3/4 in. (10m) centerline to centerline by 4 in. (102mm) bore, double-acting cylinders; retract to 9 ft. 10 in. (3m) overall width. Mechanical spin-locks are provided on each vertical jack to secure outriggers at any level. Quick disconnect hose couplings are provided to facilitate removal of outrigger beams and jacks when necessary. The four steel outrigger floats have a ground-bearing surface area of 714 sq. in. (4607cm<sup>2</sup>) each.

NOTE: Partial outrigger spread of 26 ft. 3 in. (8m) is required for 3 maximum capacity lifts. Full outrigger spread (32 ft. 9-3/4 in. (10m)) is required for all other on-outrigger lifts.

**FRONT END STABILIZER** - A fifth hydraulic vertical jack cylinder with 30 1/2 in. (775mm) diameter steel float and integral holding valves mounted in the front frame section of the chassis to permit 360° lifting capability. The steel outrigger float is easily removed for highway travel. Controls for the fifth outrigger cylinder are located on each side of the carrier frame.

**OUTRIGGER CONTROLS** - Independent operation of all outrigger functions are controlled from either side of the carrier frame by push-button electrical control. Sequence control operation eliminates unintentional outrigger actuation. Sight leveling bubbles are located on each side of the carrier frame.

**FRAME** - High-strength, all-welded construction with triple box-type design between the outriggers and integrally-welded outrigger housings.

**MAIN TRANSMISSION** - ZF "Transmatic" type 4S-150GP 8-speed synchromesh with ZF type WSK torque converter and automatic lock-up clutch. Main gear ratios are manually shifted, with Pneumatic shift for high-low range.

Ratios: Low range - 7.97, 5.89, 4.36, 3.34  
High range - 2.32, 1.72, 1.27, 1.00  
Reverse - 11.69

Torque converter stall ratio: 2.54:1

Torque converter has automatic lock-up clutch with accelerator pedal kickdown unlock facility operating within a limited rpm range.

Main clutch is Fichtel and Sachs 16.54 in. (420mm) diameter single plate type used only during gear selection. Integral hydraulic retarder.

**TRANSFER CASE** - ZF type A800-3D, single-speed, ratio 1.02:1. Differential between front and rear drivelines automatically compensates for differences in turning circles between front and rear driving axles.

**UNIVERSAL JOINTS** - Needle roller-bearing type.

**AXLES** - Kessler fabricated, high-strength steel, rectangular section, 29,895 lbs. (13,558 kg) capacity at 38.53 mph (62 km/hr). Drive axles are planetary type. Differential lock provided for maximum traction.

FRONT AXLES - 1. Steering/driving with 8.47:1 ratio.  
2. Steering/non driving (drop bed).  
3. Steering/non driving.

REAR AXLES - 4. Non steering/non driving  
5. Non steering/non driving (drop bed)  
6. Steering/through driving with lockable interaxle differential 8.47:1 ratio.  
7. Steering/through driving with lockable interaxle differential and 8.47:1 ratio.  
8. Steering/driving with 8.47:1 ratio.

**SUSPENSION** - Hydro-gas design with suspension cylinders; two units per axle mounted on axle beam. Suspension cylinders are longitudinally interconnected in groups of four on each side of carrier, with twin hydraulic accumulator units for each group. Circuits are protected by individual automatic isolation valves. Cylinder and accumulator isolation valves for suspension lockout. Front axle system partially inter-active with rear axle system. Steeply progressive spring rate resists lateral roll action and separate interconnection along each side of the carrier between rebound chambers of the suspension cylinders ensures superior suspension damping. Lockable vandal-proof covers for suspension operating levers. Built-in pressure gauges are provided for routine suspension checks.

Suspension system is protected from peak pressure loads by a main relief valve which is tested and sealed by TUV. Axles are located by top and bottom radius rods and a diagonal panhard rod, all with resilient mountings.



**STEERING GEAR** - ZF semi-integral type. 44 GPM (166 Lpm) power steering pump with maximum operating pressure of 1450 PSI (102 kg/cm<sup>2</sup>). Designed in conformity with EEC Regulations.

**AUXILIARY STEERING** - Main power-steering system is supplemented by a ZF emergency system designed in accordance with EEC Regulations. Emergency power-steering pumps of 40.6 GPM (154 Lpm) combined capacity at 870 PSI (61 kg/cm<sup>2</sup>) maximum operating pressure are V-belt driven from drive line.

**TIRES** - 16, single, 14.00 X 24 - 24 PR HCT. \*Optional are Michelin 14.00 R 24 XVC tube-type radials with highway tread.

**TIRE INFLATION KIT** - Quick connect air outlet located at midpoint either side of carrier. Includes tire connector and 36.09 ft. (11 m) length of reinforced, rubber tubing.

**WHEELS** - Pressed steel disc, 10:00 X 24 (254 X 609.6mm).

**SERVICE BRAKES** - Full-air on all wheels, single wedge actuation type. Brake drum size: 19-5/8 in. X 6-1/4 in. (500 X 160mm). System divided into two separate circuits: one circuit operates brakes on axles 1, 3, 5 and 7; second circuit operates brakes on axles 2, 4, 6 and 8. Circuit protection valves for each circuit ensure system integrity in case of component malfunction.

8 air tanks have combined capacity of 11,287 cu. in. (1.85 cu. m) construction in accordance with EEC regulations.

**EMERGENCY/PARKING BRAKES** - Spring-applied emergency chambers on the five rear most axles with air pressure release capability.

**ELECTRICAL SYSTEM** - 24-volt negative ground. Highway lighting and reflectors conforming to EEC regulations.

**CAB** - Two-man, full width design, left-hand drive, fiber glass reinforced polymer compound construction with acoustical treatment. All windows fitted with safety glass to EEC standards. Also included are windshield wipers and washers, windshield defroster, crank down side windows, lockable doors, dual rear view mirrors, twin cab, hot water type heaters with 40,950 BTU/hr (12 kw) total capacity, full diesel engine instrumentation and controls, sun visors, coat hooks, ashtray, door-operated internal cab light, air cleaner filter restriction indicator and 3.3 lbs. (1.5 kg) fire extinguisher.

**CAB INSTRUMENTATION** - Tachograph, tachometer, voltmeter, hourmeter, engine oil pressure gauge, water temperature gauge, torque converter temperature gauge, hydraulic oil temperature gauge, (2) air pressure gauges and low air pressure audio-visual warning indicator. Indicator lights for monitoring all carrier system functions and fuel level gauge.

**MISCELLANEOUS STANDARD EQUIPMENT** - Two front and two rear frame mounted towing loops, ether injection cold-starting aid, emergency air couplings, tool kit, front-mounted overall width markers, side marker lights and reflectors, flashing beacon and superstructure access ladders, spare tire rack.

\*Denotes Optional Equipment  
†Patented Grove Feature  
††Patent Pending

# SPECIFICATIONS

## ENGINE SUPERSTRUCTURE

M. A. N. D2566 MTE DIESEL			
<b>TYPE</b>	6 Cylinder OHV	<b>STARTING SYSTEM</b>	24 volt, negative ground
<b>BORE &amp; STROKE</b>	4.92 in. X 6.1 in. (125mm X 155mm)	<b>COMBUSTION SYSTEM</b>	4-cycle, turbocharged direct injection
<b>DISPLACEMENT</b>	696 cu. in. (11405 cm <sup>3</sup> )	<b>COOLING SYSTEM</b>	Liquid, 9 gallons (34 liters)
<b>HORSEPOWER @ 2100 RPM</b>	256 (SAE GROSS)	<b>FUEL CAPACITY</b>	100 gallons (379 liters)
<b>HORSEPOWER @ 2100 RPM</b>	232 (SAE NET)	<b>ALTERNATOR</b>	90 AMP, 12 Volt
<b>HORSEPOWER @ 2100 RPM</b>	260 (DIN)	<b>BATTERY</b>	(4) 12-V, 475 CCA @ 0°F
<b>GOVERNED RPM</b>	2100	<b>AIR CLEANER</b>	Dry Type, Single-Stage
<b>TORQUE @ 1500 RPM</b>	644 ft. lbs. (SAE NET) (89 Kgm)	<b>AIR COMPRESSOR</b>	11.9 CFM (337 Liters/min.)
<b>TORQUE @ 1500 RPM</b>	718 ft. lbs. (DIN) (993 Kgm)	<b>HOURMETER</b>	Standard (10,000 hour)
<b>ELECTRICAL SYS.</b>	12 volt, negative ground		

•CCA - Cold Cranking Amperage per battery

**NOTE:** Performance data will vary plus or minus 10% due to variations in engine performance and operating conditions.

## SPEED AND GRADEABILITY

GEAR	MPH	KM/H	GRADE % RANGE	% OF GRADEABILITY AT STALL (Range)
1st	5	8	29.1 in First	34% in First
2nd	6.8	11	to	to
3rd	9.3	15	2.3 in Eighth	3% in Eighth
4th	11.8	19		
5th	17.4	28		
6th	23.6	38		
7th	31.9	51		
8th	40.5	65		

**MAXIMUM SPEED - With Converter locked at Governed RPM**

**NOTE:** Performance is based on 106 tons (96MT) GVW and standard engine rating conditions using standard tires, transmission and axles. Data may vary plus or minus 10% due to variations in engine performance and vehicle weights.

**TRANSPORT WEIGHT - 106 tons (96MT) GVW or 13 tons (12MT) per axle achievable within certain guidelines and with counterweight removed for highway travel. Consult Factory for specific weights since weights may vary depending on configuration specified.**

# ENGINE - CARRIER

## M.A.N. D2542 MTE DIESEL

<b>TYPE</b>	12 Cylinder OHV	<b>STARTING SYSTEM</b>	24 volt, negative ground
<b>BORE &amp; STROKE</b>	4.92 in. X 5.59 in. (125mm X 142mm)	<b>COMBUSTION SYSTEM</b>	4-cycle, turbocharged direct injection
<b>DISPLACEMENT</b>	1276 cu. in. (20910 cm <sup>3</sup> )	<b>COOLING SYSTEM</b>	Liquid, 30 gallons (114 liters)
<b>HORSEPOWER @ 2300 RPM</b>	517 (SAE GROSS)	<b>FUEL CAPACITY</b>	200 gallons (757 liters)
<b>HORSE POWER @ 2300 RPM</b>	426 (SAE NET)	<b>ALTERNATOR</b>	27 AMP, 28 Volt
<b>HORSEPOWER @ 2300 RPM</b>	525 (DIN)		
<b>GOVERNED RPM</b>	2300	<b>BATTERY</b>	(4) 12-V, 475 CCA @ 0° F.
<b>TORQUE @ 1500 RPM</b>	1078 ft. lbs. (SAE NET) (149 Kgm)	<b>AIR COMPRESSOR</b>	19 CFM (538 Liters/min)
<b>TORQUE @ 1500 RPM</b>	1282 ft. lbs. (DIN) (177 Kgm)	<b>AIR CLEANER</b>	Single-stage, dry type
<b>ELECTRICAL SYS.</b>	24 volt, negative ground	<b>HOURLY METER</b>	Standard (10,000 hour)

\*CCA - Cold cranking amperage per battery  
Carrier Engine conforms to EEC & EPA requirements

The most advanced design

# CARRIER MOUNTED CRANES

15 thru 250-Tons

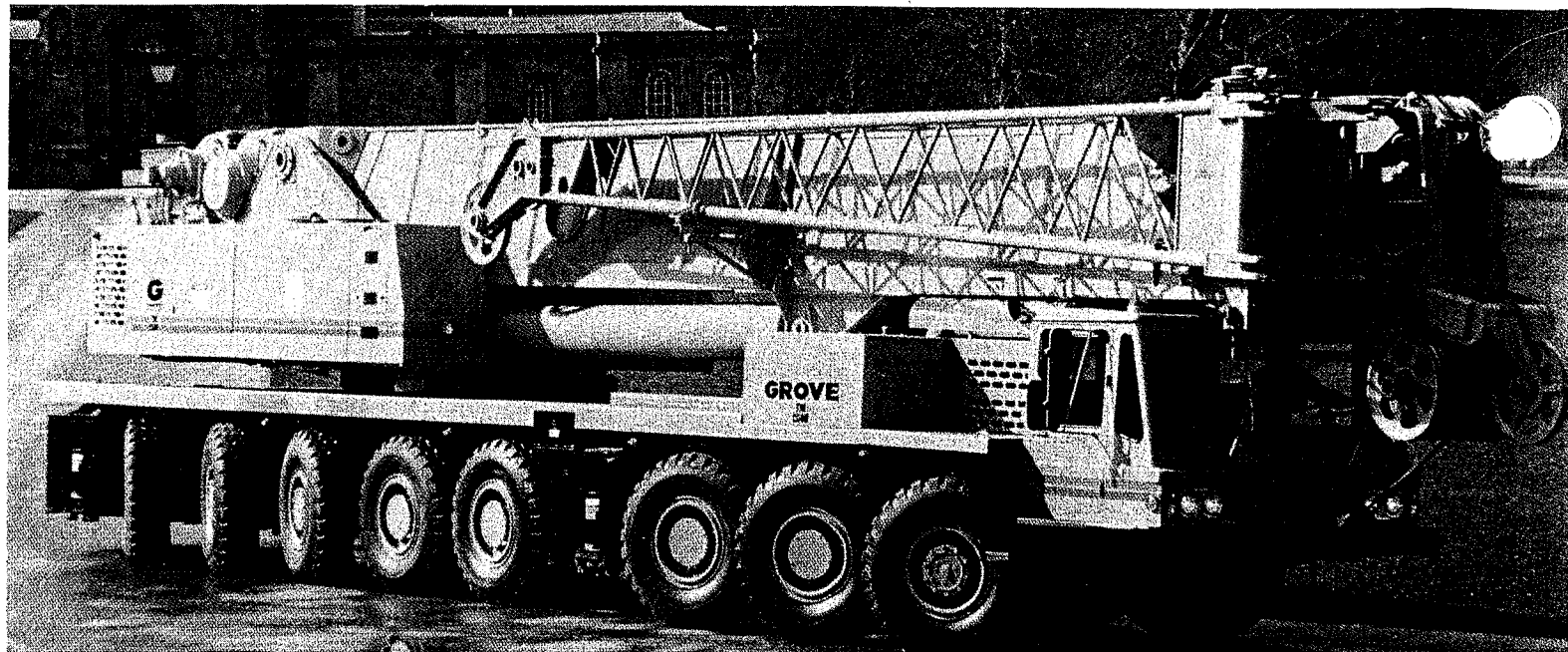

## GROVE MANUFACTURING COMPANY

Division of Kidde, Inc

**KIDDE**

Box 21, Shady Grove, Pennsylvania 17256

Phone: (717) 597-8121 Telex: 842308 Cable: GROVE MFG

WORLD  
LEADER  
IN  
**HYDRAULIC  
CRANES**

FORM NO. SBTM2500-10M



# TM2500A

300 TON CAPACITY  
47 ft. - 208 ft. BOOM

(FULL POWER TRAP LOCK)  
PCSA CLASS 10-1400  
85% OF TIPPING

## RATED LIFTING CAPACITIES IN POUNDS ON OUTRIGGERS - 360°

### WITH 60,000 lb. COUNTERWEIGHT

Radius in Feet	Main Boom Length in Feet						34ft. Ext. & 175 ft. (3° Offset)
	47	47	79	111	143	175	
10	600,000 (75.5)						See Warning Note 16
13	500,000 (72.5)	500,000 (72.5)	298,000 (80)				
15	435,500 (69.5)	435,500 (69.5)	285,000 (78.5)	187,500 (82.5)			
20	338,500 (62)	338,500 (62)	246,500 (75)	186,000 (80)	128,000 (83)		
25	267,000 (53.5)	267,000 (53.5)	212,500 (71)	175,000 (77)	128,000 (81)		
30	217,500 (44)	224,000 (44)	180,000 (67)	153,000 (74.5)	128,000 (79)	82,000 (83)	
35	157,500 (32)	176,000 (32)	159,000 (62.5)	135,000 (71.5)	120,000 (77)	82,000 (81)	44,100 (82.5)
40			140,000 (58)	120,000 (69)	113,000 (75)	82,000 (79.5)	44,100 (81)
45	See Warning Note 15		115,500 (53.5)	108,000 (66)	98,000 (73)	79,050 (78)	44,100 (79.5)
50			101,500 (48.5)	98,000 (63)	89,650 (70.5)	72,650 (76)	44,100 (78)
60			71,200 (36.5)	77,000 (57)	77,550 (66)	62,250 (72.5)	41,200 (75)
70			53,750 (17.5)	58,250 (50)	62,500 (61.5)	54,300 (69)	38,150 (72.5)
80				45,000 (42.5)	49,000 (56.5)	47,500 (65)	35,550 (69.5)
90				35,000 (33)	39,250 (51.5)	41,100 (61)	32,350 (66.5)
100				27,250 (19.5)	31,500 (46)	35,500 (57)	28,900 (63)
110					24,950 (39.5)	29,500 (52.5)	25,950 (60)
120					19,650 (31.5)	24,250 (48)	23,450 (56.5)
130					15,550 (20.5)	19,850 (43)	21,300 (53)
140						16,100 (37.5)	18,200 (49.5)
150						13,100 (30.5)	15,200 (45.5)
160						10,150 (21.5)	12,450 (41)
170							10,050 (36)
180							8,160 (30.5)
190							6,340 (23.5)
200							4,430 (11)

Min. boom angle (deg.) for indicated length for no load stability with 60,000 lb. counterweight:

0	0	0	0	0	5
---	---	---	---	---	---

A6-829-005877 & -005723 & -005382A

NOTE: Boom angles are in degrees.

### WITHOUT COUNTERWEIGHT

Radius in Feet	Main Boom Length in Feet						34ft. Ext. & 175 ft. (3° Offset)
	47	47	79	111	143	175	
10	600,000 (75.5)						See Warning Note 16
13	500,000 (72.5)	500,000 (72.5)	298,000 (80)				
15	435,500 (69.5)	435,500 (69.5)	285,000 (78.5)	187,500 (82.5)			
20	338,500 (62)	338,500 (62)	246,500 (75)	186,000 (80)	128,000 (83)		
25	267,000 (53.5)	223,500 (53.5)	212,500 (71)	175,000 (77)	128,000 (81)		
30	217,500 (44)	164,500 (44)	163,500 (67)	153,000 (74.5)	128,000 (79)	82,000 (83)	
35	157,500 (32)	119,500 (32)	121,500 (62.5)	123,000 (71.5)	120,000 (77)	82,000 (81)	44,100 (82.5)
40			91,350 (58)	92,650 (69)	93,700 (75)	82,000 (79.5)	44,100 (81)
45	See Warning Note 15		72,100 (53.5)	72,900 (66)	74,050 (73)	79,050 (78)	44,100 (79.5)
50			56,800 (48.5)	58,100 (63)	59,250 (70.5)	69,300 (76)	44,100 (78)
60			36,750 (36.5)	38,200 (57)	45,450 (66)	48,200 (72.5)	41,200 (75)
70			24,200 (17.5)	26,950 (50)	33,150 (61.5)	34,950 (69)	38,150 (72.5)
80				18,450 (42.5)	23,150 (56.5)	26,950 (65)	29,550 (69.5)
90				11,450 (33)	16,100 (51.5)	21,050 (61)	22,600 (66.5)
100				6,520 (19.5)	11,100 (46)	15,700 (57)	17,400 (63)
110					6,460 (39.5)	11,250 (52.5)	13,250 (60)
120					2,940 (31.5)	7,540 (48)	9,800 (56.5)
130						4,600 (43)	6,970 (53)
140						1,700 (37.5)	4,200 (49.5)
150							1,870 (45.5)

Min. boom angle (deg.) for indicated length for no load stability without counterweight:

0	0	0	5	28	35	43
---	---	---	---	----	----	----

A6-829-005878 & -005723 & -005382A

NOTE: Boom angles are in degrees.

36 ft. and 54 ft. FIXED JIB  
CAPACITIES IN POUNDS  
ON OUTRIGGERS - 360°  
with 60,000 lb. Counterweight

Main Boom Angle	36 ft. JIB				54 ft. JIB			
	10° OFFSET		30° OFFSET		10° OFFSET		30° OFFSET	
	Ref. Rad.(ft.)	Load (lbs.)	Ref. Rad.(ft.)	Load (lbs.)	Ref. Rad.(ft.)	Load (lbs.)	Ref. Rad.(ft.)	Load (lbs.)
84°	36.0	27,250	45.6	18,100	42.1	21,000	55.5	11,500
80	52.5	24,850	61.7	17,150	59.5	19,000	72.8	10,900
75	72.8	21,900	81.3	15,950	80.8	16,600	94.0	10,050
70	92.4	19,550	100.3	15,000	101.6	14,700	114.4	9,430
65	111.4	17,650	118.7	14,250	121.7	13,250	134.0	8,920
60	129.6	16,200	136.0	13,700	140.8	12,050	152.6	8,510
55	146.8	13,350	152.3	12,500	158.9	11,100	170.0	8,200
50	162.9	10,370	167.6	9,720	175.7	9,040	186.1	7,980
45	177.8	8,000	181.5	7,640	191.2	6,930	200.8	6,520
40	191.3	6,110	194.0	6,100	205.3	5,130	214.0	4,930
35	203.4	4,560			217.8	3,760		
30	214.0	3,310			228.7	1,970		

A6-829-005421

### FIXED JIB CAPACITY NOTES:

- Prior to lifting any loads on the 36 ft. (11.0m) and 54 ft. (16.5m) fixed jibs, ensure jib is properly installed and erected. Maintain the correct offset angles. Refer to Operator's and Safety Handbook for instructions.
- Capacities for 36 ft. (11.0m) and 54 ft. (16.5m) fixed jibs are for two-part line lifting crane service only, with Krueger dynamometer installed at dead end.
- Capacities are based on structural strength of 36 ft. (11.0m) and 54 ft. (16.5m) jibs and 34 ft. (10.4m) boom extension combination at given main boom angles regardless of main boom length. (Ref. Radius in feet (meters) is for fully extended (175 ft.) boom length only. The Krueger LMI System will give an accurate radius indication for this condition only.)  
**WARNING:** Operation of this crane with loads greater than the capacities listed is strictly prohibited. Machine tipping with every jib occurs rapidly and without advance warning.
- 36 FT. (11.0m) JIB WARNING:** With 36 ft. (11.0m) jib plus 34 ft. (10.4m) boom extension combination and main boom fully extended, the boom angle must not be less than 30° since loss of stability will occur causing a tipping condition.  
**54 FT. (16.5m) JIB WARNING:** With 54 ft. (16.5m) jib plus 34 ft. (10.4m) boom extension combination and main boom fully extended, the boom angle must not be less than 30° since loss of stability will occur causing a tipping condition.
- FIXED JIB ERECTION NOTES:**
  - Maximum length of main boom for purpose of erecting jib below 30° main boom angle is:  
111 ft. (33.8m) with 34 ft. (10.4m) boom extension plus 36 ft. (11.0m) or 54 ft. (16.5m) jib.
  - Do not attempt to erect jib over front of machine.
- WARNING:** Capacities listed are with fully extended (32 ft. 10 in. (10m) outriggers only.
- WARNING:** Lifting with any jib with counterweight removed is prohibited.

### HOOK ELEVATION DIAGRAM UNLADEN BOOM

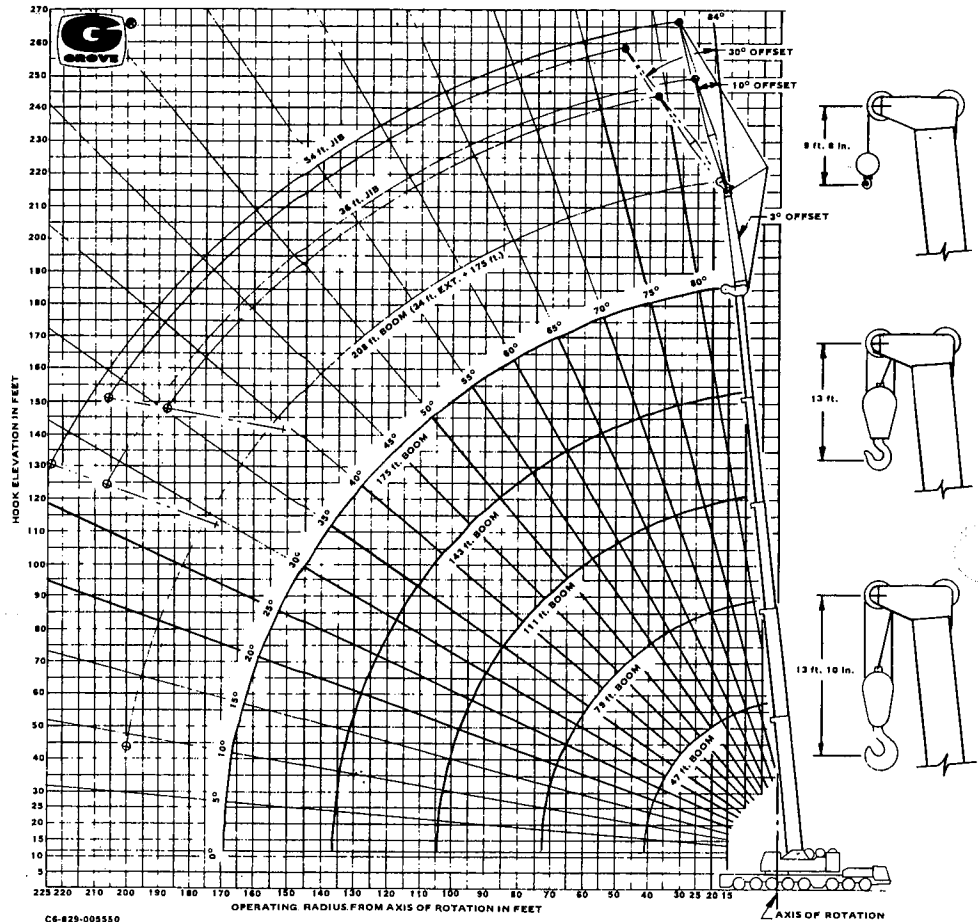

### WEIGHT REDUCTION FOR LOAD HANDLING DEVICES

#### HOOKBLOCKS

300 Ton, 10 sheave . . . . .	6920 lbs. (3139 kg)
150 Ton (135MT) 6 sheave . . . . .	4200 lbs. (1905 kg)
50 Ton (45MT) 2 sheave . . . . .	2996 lbs. (1359 kg)
15 Ton (13.6MT) headache ball . . . . .	1220 lbs. (553 kg)
Auxiliary boom head . . . . .	510 lbs. (231 kg)

34 ft. BOOM EXTENSION	
†Stowed	908 lbs.
†Erected	4,815 lbs.
36 ft. FIXED JIB & 34 ft. BOOM EXT. COMB.	
†Erected	22,037 lbs.
††Erected	4,373 lbs.
54 ft. FIXED JIB & 34 ft. BOOM EXT. COMB.	
†Erected	30,063 lbs.
††Erected	7,488 lbs.

†Reduction of main boom capacities.  
††Reduction of 34 ft. Ext. capacities.

**NOTE:** All Load Handling Devices and Boom Attachments are Considered Part of the Load and Suitable Allowances MUST BE MADE for Their Combined Weights. Weights are for Grove furnished equipment.



### GROVE MANUFACTURING COMPANY

Division of Kidde, Inc.

### KIDDE

Box 21, Shady Grove, Pennsylvania 17256  
Phone: (717) 597-8121 Telex: 842308 Cable: GROVE MFG

Distributed by:

DATE: 1181-1M  
Printed in U.S.A.

# TM2500A

300 TON CAPACITY  
47 ft. - 208 ft. BOOM

(FULL POWER TRAP LOCK)  
PCSA CLASS 10-1400  
85% OF TIPPING

## NOTES FOR LIFTING CAPACITIES CONT'D.

### OPERATION:

1. Rated loads at rated radius shall not be exceeded. Do not tip the machine to determine allowable loads. For clamshell operation, weight of load must not exceed 80% of rated lifting capacities.
2. Rated loads do not exceed 85% of the tipping load as determined by S.A.E. Crane Stability Test Code J-765a.
3. Rated loads include the weight of hook block, slings and auxiliary lifting devices and their combined weights shall be subtracted from the listed ratings to obtain the net load which may be lifted.
4. Load ratings are based on freely suspended loads. No attempt shall be made to move a load horizontally on the ground in any direction.
5. Rated loads do not account for wind on lifted load or boom. It is recommended when wind velocity is above 20 mph (32 km/h), rated loads and boom lengths be appropriately reduced.
6. Rated loads are for lift crane service only.
7. Do not operate at a radius or boom length where capacities are not listed. At these positions, the crane may overturn without any load on the hook.
8. When either boom length or radius or both are between values listed, the smallest load shown at either the next larger radius or boom length shall be used.
9. For safe operation, the user shall make due allowances for his particular job conditions, such as: soft or uneven ground, out of level conditions, high winds, side loads, pendulum action, jerking or sudden stopping of loads, hazardous conditions, experience of personnel, two machine lifts, traveling with loads, electric wires, etc. Side pull on boom or jib is extremely dangerous.
10. Handling of personnel from the boom is not authorized except with equipment furnished and installed by Grove Manufacturing Company.
11. Keep load handling devices a minimum of 18 inches (45.7 cm) below boom head at all times.
12. The boom angle before loading should be greater than the loaded boom angle to account for deflection.
13. Capacities appearing above the bold line are based on structural strength and tipping should not be relied upon as a capacity limitation.
14. Radii less than 40 ft. (12m) not recommended when lifting over the front of machine.
15. Capacities for the 47 ft. (14.3m) boom length shall be lifted only with boom fully retracted and telescope cylinder unlatched.
16. For boom length less than 208 ft. (63.4m) with 34 ft. (10.4m) boom extension erected, the rated loads are determined by boom angle only in the column headed by 208 ft. (63.4m). For boom angles not shown, use rating of next lower boom angle. For this load column, the 34 ft. (10.4m) boom extension operation mode is to be selected on the Krueger LMI. **WARNING:** With boom extension erected, the Krueger LMI calibration will apply only for fully extended main boom.

### DEFINITIONS:

1. Operating Radius: Horizontal distance from a projection of the axis of rotation to the supporting surface before loading to the center of the vertical hoist or tackle with load applied.
2. Loaded Boom Angle (Shown in Parenthesis on Main Boom Capacity Chart): is the angle between the boom base section and the horizontal, after lifting the rated load at the rated radius with the rated boom length.
3. Working Area: Areas measured in a circular arc about the center line of rotation as shown on the working area diagram.
4. Freely Suspended Load: Load hanging free with no direct external force applied except by the lift cable.
5. Side Load: Horizontal force applied to the lifted load either on the ground or in the air.

## LIFTING AREA DIAGRAM

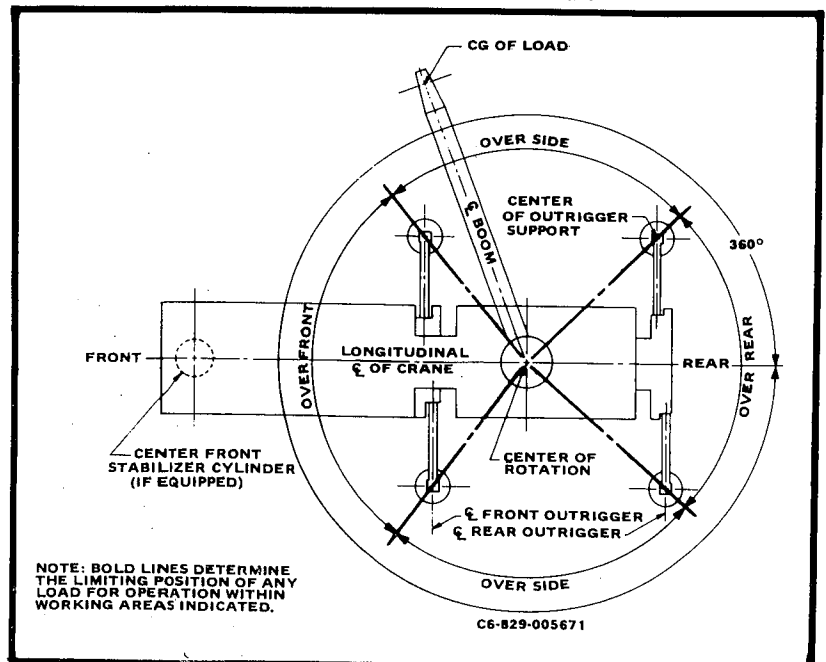

# GROVE®

## FULL HYDRAULIC

# CARRIER-MOUNTED CRANE

### NOTES FOR ON OUTRIGGERS

**WARNING:**  indicates capacities to be lifted with 26 ft. 3 in. (8m) outrigger spread. All other capacities will require a 32 ft. 10 in. (10m) outrigger spread. For 32 ft. 10 in. (10m) outrigger spread - fully extend outrigger beams to mechanical stops. For 26 ft. 3 in. (8m) outrigger spread - fully extend outrigger beams to mechanical stops then retract to 26 ft. 3 in. (8m) markings on beams.

Failure to completely extend outrigger beams to the full 32 ft. 10 in. (10m) spread may cause structural failure or tipping of crane.

### NOTES FOR LIFTING CAPACITIES

#### GENERAL:

- Rated loads as shown on capacity chart pertain to this crane as originally manufactured and equipped. Modifications to the crane or use of optional equipment other than that specified can result in a reduction of capacity. Use only the jib or boom extension supplied with this crane, do not substitute jibs or boom extensions without the written approval of Grove Mfg. Co.
- Construction equipment can be hazardous if improperly operated or maintained. Operation and maintenance shall be in compliance with the information in the Operator's and Safety Handbook, Service and Parts manuals supplied with this crane. If these manuals are missing, order replacements from the manufacturer.
- The operator and other personnel associated with this crane shall fully acquaint themselves with the latest applicable American National Standards Institute (ANSI) Safety Standards for cranes.
- WARNING:** Do not attempt to operate this crane unless you have read and are thoroughly familiar with the Operator's and Safety Handbook.
- Consult the Operator's and Safety Handbook for procedure in removing and reinstalling the counterweight. The counterweight must be removed before traveling.

#### SETUP:

- The crane shall be leveled on a firm supporting surface. Depending on the nature of the supporting surface, it may be necessary to have structural supports of sufficient strength under the outrigger floats or tires to spread the load to a larger bearing surface.
- For outrigger operation, outriggers shall be extended to the position stated, with tires raised free of crane weight before operating the boom or lifting loads.
- The front jack cylinder shall be set in accordance with the written procedure.
- With certain boom and hoist tackle combinations, maximum capacities may not be obtainable with standard cable lengths.
- Rotation resistant wire rope is best suited for single line lifting operations. Consult the wire rope manufacturer for specific recommendations concerning multiple part reeving.
- Do not transport crane with boom extension or jib erected.
- WARNING:** Never remove boom from boom rest, operate boom, or rotate superstructure unless outriggers are properly extended and set.
- Do not lower boom more than -2° over rear - lift cylinder box will contact carrier deck.
- WARNING:** Never erect jibs or boom extensions unless outriggers are fully extended to 32 ft. 10 in. (10 m) and set.
- WARNING:** Load transfer device and/or boom trailer must be disconnected from carrier before making any lifts. Ensure that suspension valve No. 6 is in CARRIER position after disconnecting trailer. After extension of outrigger beams and jack cylinders, retract axles for additional ground clearance. -See Operator's and Safety Handbook for specific instructions.
- WARNING:** Prior to lifting with fixed length boom, ensure that all boom sections are pinned, telescope cylinder is retracted, and boom power switch is turned off. For load chart capacities shown, boom lengths must be obtained in specific combinations of sections as indicated below:

BOOM LENGTH:	Inner-mid Section		Mid Section		Outer-mid Section		Fly Section	
	Ext.	Ret.	Ext.	Ret.	Ext.	Ret.	Ext.	Ret.
47 ft. (14.3 m) (fully retracted)		X		X		X		X
79 ft. (24.1 m)	X			X		X		X
111 ft. (33.8 m)	X		X			X		X
143 ft. (43.6 m)	X		X		X			X
175 ft. (53.3 m) (fully extended)	X		X		X		X	

Starting with fully retracted boom, first select and extend outermost boom section required for given boom length. Pin extended section, unlatch and retract tele cylinder to pick-up next outermost section. Continue to follow sequence above until desired boom length is obtained. Reverse this procedure when retracting boom.



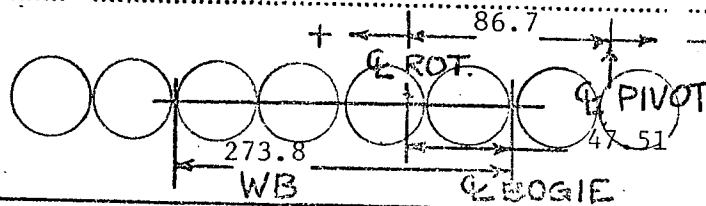

WEIGHTS  
 SUBJECT TO CHANGE  
 -VERIFY-

DESCRIPTION	CG TO CL BOGIE	GROSS LBS.	FRONT LBS.	REAR LBS.
Max. Axle Loads Allowed (12 MT/Axle)			(105,821)	(105,821)
Max. Axle Load Allowed (13.5 MT/Axle)			(119,048)	(119,048)
<b>CARRIER</b>				
Complete with: Full Fuel & Hyd. Oil;				
Less Spare Tire & O.R. Floats	+114.92	111,308	46,720	64,588
<b>SUPERSTRUCTURE</b>				
Complete with: Full Fuel & Hyd. Oil;				
Model 54 Main Hoist with 1500' of 1-1/8"				
Cable, Cable Idler & Follower; Model 44'				
Aux. Hoist with 950' of 1" Cable, Cable				
Idler & Follower	- 26.63	47,019	4,573	51,592
<b>LIFT CYLINDERS</b>				
Complete with: Oil & Lower Pins	+150.42	10,305	5,661	4,644
<b>BOOM</b>				
47'-175' Single Cylinder 5-Section				
Latched Boom with: $\frac{3}{13}$ Sheave Boom Nose				
& Swingaway Tele Boom Extension Carrier				
Brackets	+247.17	67,845	61,247	6,598
<b>COUNTERWEIGHT (84,637#)</b>				
Center Section (w/2 Slabs)	-160.49	27,521	16,123	43,644
Right Hand & Left Hand Wings	-160.49	57,116	33,479	90,595

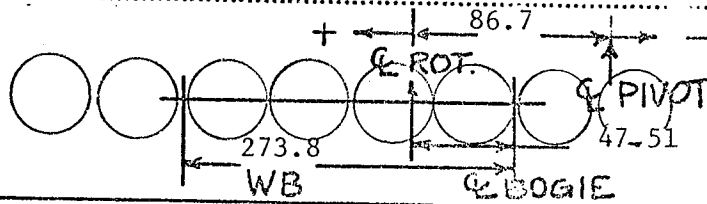

WEIGHTS  
 SUBJECT TO CHANGE  
 -VERIFY-

DESCRIPTION	CG TO CL BOGIE	GROSS LBS.	FRONT LBS.	REAR LBS.
SWINGAWAY TELE BOOM EXTENSION (Carrier Brkts. Incl. w/Boom)	+326.66	7,655	9,133	1,478
SECOND AUXILIARY HOIST (Gearmatic 44 w/Idler & Follower, & 950' of 1" dia. (18x19) Cable, Remove 2 Cwt Slabs (3186#)	(HOIST) -163.18 (CWT) -160.49	5,075 3,186	3,025 1,867	8,100 5,053
OUTRIGGER FLOATS (5) (Stowed on Carrier)	- 94.08	732	252	984
SPARE TIRE	+375.30	456	625	169
HOOKBLOCKS				
300 Ton (12 Sheave) V		9,033		
150 Ton (6 Sheave)		3,990		
50 Ton (2 Sheave)		3,000		
HEADACHE BALL 15 Ton		1,237		
KRUEGER LOAD MOMENT INDICATOR	+135.62	400	198	202
AUXILIARY BOOM NOSE	+549.02	510	1,023	513
REMOVE				
Front O.R. Beams	+200.44	11,090	8,119	2,971
Rear O.R. Beams	-144.87	11,090	5,868	16,958
Main Hoist Cable	- 79.18	3,750	1,085	4,835
Aux. Hoist Cable	-118.18	1,900	820	2,720
Second Aux. Hoist Cable	-163.18	1,900	1,132	3,032