









-  Mercedes Benz
390 kW
-  Mercedes G 280
with optional VIAB
turbo retarder clutch
-  MEGATRAK®
-  MAXbase
-  ECO Mode
-  Crane Control System
-  MEGAFORM®
TWIN-LOCK®

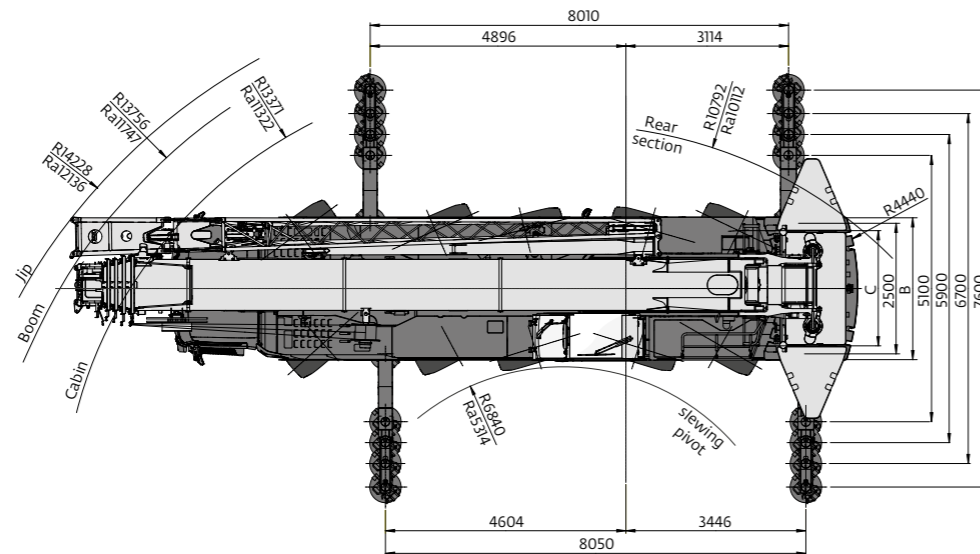
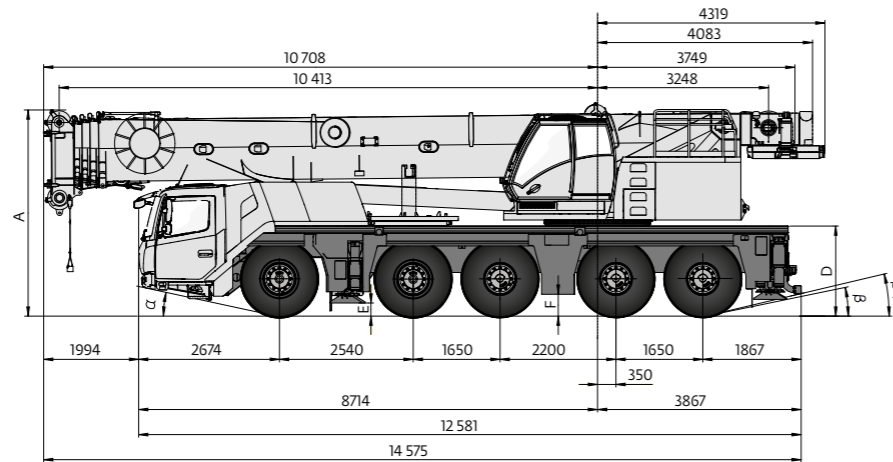

	A	A 105 mm**	B	C	D	E	F	a	β	β ₁
R14,00/R25	3935	3805	2750	2298	1732	272	431	12*	12*	13*
R16,00/R25	3998	3868	2750	2276	1795	335	494	14*	15*	16*
R20,50/R25	3998	3868	2900	2296	1795	335	494	14*	15*	16*

* lowered, abgeseenkt, surbaissée, abbassato, rebaja, сниженный

Regional headquarters

Americas

Milwaukee, Wisconsin, USA
Tel: +1 414 760 4600

Shady Grove, Pennsylvania, USA
Tel: +1 717 597 8121
Fax: +1 717 597 4062

Europe and Africa

Dardilly, France -
TOWERS
Tel: +33 (0)4 72 18 20 20
Fax: +33 (0)4 72 18 20 00

Wilhelmshaven, Germany -
MOBILE
Tel: +49 (0) 4421 294 0
Fax: +49 (0) 4421 294 4301

Middle East and Greater Asia-Pacific

Singapore
Tel: +65 6264 1188
Fax: +65 6862 4040

Dubai, UAE
Tel: +971 4 8862677
Fax: +971 4 8862678/79

China

Shanghai, China
Tel: +86 21 6457 0066
Fax: +86 21 6457 4955



This document is non-contractual. Constant improvement and engineering progress make it necessary that we reserve the right to make specification, equipment, and price changes without notice. Illustrations shown may include optional equipment and accessories and may not include all standard equipment.

Die Angaben in diesem Dokument erfolgen ohne Gewähr. Wir verbessern unsere Produkte ständig und integrieren den technischen Fortschritt. Aus diesem Grund behalten wir uns das Recht vor, die technischen Daten, die Ausstattungsdetails und die Preise unserer Maschinen ohne Vorankündigung zu ändern.

Ce document est non-contractuel. Du fait de sa politique d'amélioration constante de ses produits liée au progrès technique, la Société se réserve le droit de procéder sans préavis à des changements de spécifications, d'équipement ou de prix. Les illustrations peuvent comporter des équipements ou accessoires optionnels ou ne pas comporter des équipements standards.

Este documento no es contractual. El perfeccionamiento constante y el avance tecnológico hacen necesario que la empresa se reserve el derecho de efectuar cambios en las especificaciones, equipo y precios sin previo aviso. En las ilustraciones se puede incluir equipo y accesorios opcionales y es posible que no se muestre el equipo normal.

Documento non contrattuale. In considerazione della sua politica di costante miglioramento dei prodotti connesso al progresso tecnico, la Società si riserva il diritto di modificare senza preavviso specifiche, equipaggiamenti o prezzi. Le illustrazioni possono contenere equipaggiamenti o accessori optional o non contenere equipaggiamenti standard.

Данный документ не является контрактным. Принимая во внимание необходимость постоянного совершенствования и модернизации мы оставляем за собой право изменять спецификации, конструкции и стоимость без предварительного уведомления. Приведенные иллюстрации могут содержать дополнительные компоненты и принадлежности, не входящие в стандартный комплект поставки оборудования.



GMK5150



150 t



41,8 m



50,8 m



88 m



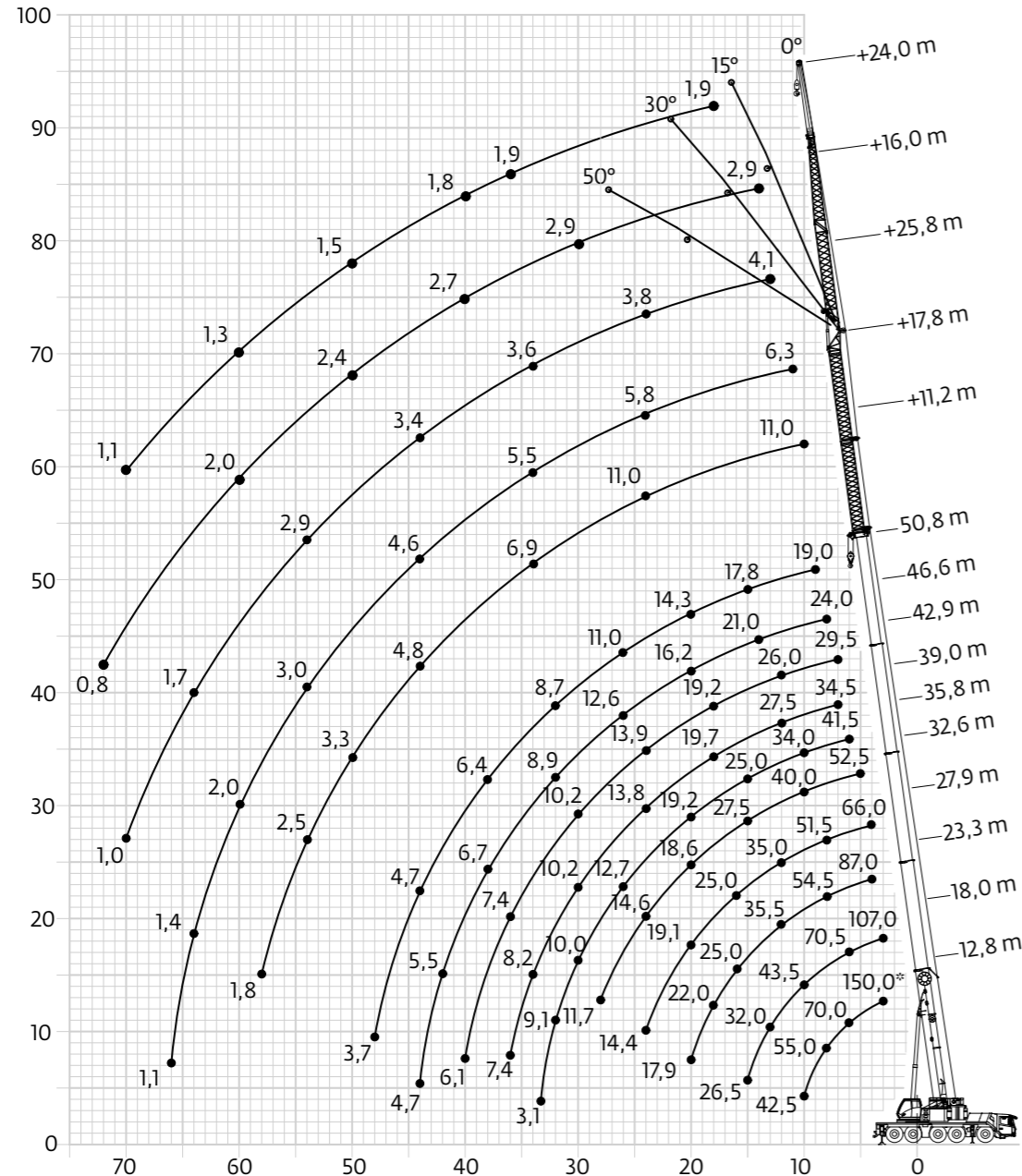





 12,8 - 50,8 m
  7,6 m
  360°
  44,5 t

 
 EN 13000

m	12,8	18,0	23,3	27,9	32,6	35,8	39,0	42,9	46,6	49,7	50,8	m
3,0	150,0*											3,0
3,0	109,0	107,0										3,0
4,0	92,0	92,5	87,0	66,0								4,0
5,0	79,5	79,5	79,5	65,0	52,5							5,0
6,0	70,0	70,5	69,5	61,0	52,5	41,5	31,5					6,0
7,0	62,0	62,5	62,0	56,0	49,5	41,5	34,5	29,5				7,0
8,0	55,0	55,5	54,5	51,5	46,0	39,5	34,5	29,5	24,0			8,0
9,0	48,0	49,0	48,0	47,5	43,0	36,5	33,5	29,5	24,0	19,7	19,0	9,0
10,0	42,5	43,5	42,5	43,0	40,0	34,0	31,5	28,5	24,0	19,7	19,0	10,0
11,0		39,0	38,5	38,5	37,5	32,0	29,5	27,0	24,0	19,6	19,0	11,0
12,0		35,5	35,5	35,0	35,0	30,0	27,5	26,0	23,0	19,5	19,0	12,0
13,0		32,0	32,0	32,0	32,5	28,0	26,0	24,5	22,0	19,1	18,8	13,0
14,0		29,5	29,5	29,0	30,0	26,5	24,5	23,5	21,0	18,4	18,4	14,0
15,0		26,5	27,0	27,0	27,5	25,0	23,0	22,5	20,0	17,7	17,8	15,0
16,0			25,0	25,0	25,5	23,5	22,0	21,0	19,3	16,9	17,1	16,0
18,0			22,0	21,5	22,0	21,0	19,7	19,2	17,7	15,4	15,6	18,0
20,0			17,9	19,1	18,6	19,2	17,8	17,4	16,2	14,2	14,3	20,0
22,0				16,5	16,0	16,5	15,8	15,7	14,9	13,1	13,1	22,0
24,0				14,4	14,6	14,4	13,8	13,9	13,8	12,0	11,9	24,0
26,0					13,2	12,7	12,9	12,2	12,6	11,1	11,0	26,0
28,0						11,7	11,2	11,4	11,3	11,2	10,4	28,0
30,0							10,0	10,2	10,2	10,0	9,6	30,0
32,0							9,1	9,1	9,1	8,9	8,9	32,0
34,0								8,2	8,2	8,0	8,0	34,0
36,0							3,1	7,4	7,4	7,3	7,2	36,0
38,0									6,7	6,7	6,5	38,0
40,0									6,1	6,1	5,8	40,0
42,0										5,5	5,3	42,0
44,0										4,7	4,7	44,0
46,0											4,3	46,0
48,0											3,7	48,0

* Over rear with special equipment • Nach hinten mit Sonderausrüstung • En arrière avec équipement special • Por la parte trasera con equipo especial
 Sul posteriore con equipaggiamento speciale • На задней частью со специальным оборудованием

	Ininitely variable • Stufenlos • Progressivement variable • Infinitamente variable • Infinitamente variabile • Плавно-изменяемый	Rope • Seil • Câble • Cable Fune • Канат	Max. Single line pull • Max. Seilzug • Effort maxi au brin simple • Tiro máximo por ramal • Tiro max. per singola fune • Макс. натяжение каната
	0 - 120 m/min Single line • Einfacher Strang • Brin simple • Ramal simple Tiro a fune singola • Однократная запасовка	19 mm/255 m	84 kN
	0 - 120 m/min Single line • Einfacher Strang • Brin simple • Ramal simple Tiro a fune singola • Однократная запасовка	19 mm/255 m	84 kN
	-1,5° to +83° approx. 350 s • ca. 350 s • env. 350 s • aproximadamente 350 s aproximadamente 350 s • примерно 350 с		12,8 to 50,8 m approx. 350 s • ca. 350 s • env. 350 s • aproximadamente 350 s aproximadamente 350 s • примерно 350 с